

TIMBER TOWER RESEARCH PROJECT

FINAL REPORT
MAY 6th, 2013
Skidmore, Owings & Merrill, LLP
© 2013

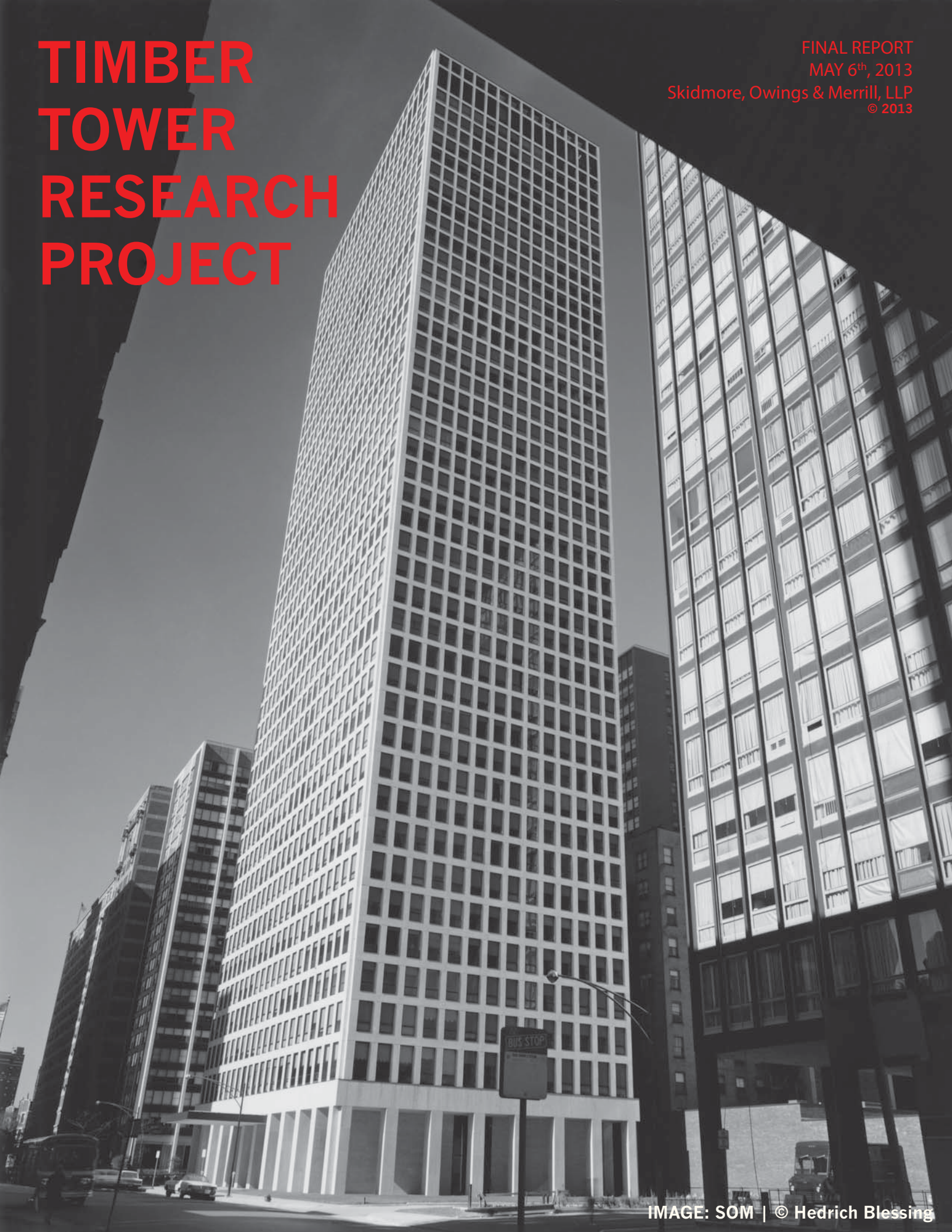

Table of Contents

- Acknowledgements
- Executive Summary
- Report Overview
- Section 1: Project Overview – Pg. 1
 - 1.1: Sustainability and Carbon Footprint
 - 1.2: The Role of Tall Buildings in Sustainability
 - 1.3: Purpose of the Research Project
 - 1.4: Research Objectives
 - 1.5: Dewitt-Chestnut Apartment Benchmark
- Section 2: Structural Design – Pg. 5
 - 2.1: Structural System Overview
 - 2.2: Structural System Description
 - 2.3: Structural Materials
 - 2.4: Gravity Resisting System
 - 2.5: Lateral Load Resisting System
 - 2.6: Foundation System
 - 2.7: Structural Considerations Related to Fire
 - 2.8: Construction considerations
- Section 3: Architectural Design – Pg. 26
 - 3.1: Architectural Design Overview
 - 3.2: Building Code Overview
 - 3.3: Core Design and Modifications from Benchmark
 - 3.4: Floor to Floor Height and Modifications from Benchmark
 - 3.5: Discipline Coordination
 - 3.6: Acoustical Performance Requirements and Design
 - 3.7: Moisture Protection and Pest Resistance
 - 3.8: Exterior Wall Design
- Section 4: Interior Architecture Design – Pg. 32
 - 4.1: Interior Architecture Design Overview
 - 4.2: Overall Organization
 - 4.3: Organization of Interior Components
 - 4.4: Structural System Impact on Interiors
 - 4.5: Rental Apartments
 - 4.6: High-End Condominiums
- Section 5: Building Services Design – Pg. 36
 - 5.1: Mechanical Systems
 - 5.2: Plumbing Systems
 - 5.3: Fire Protection Systems
 - 5.4: Electrical Systems

Table of Contents

- Section 6: Embodied Carbon Analysis of Structure – Pg. 38
 - 6.1: Overview
 - 6.2: Materials Used
 - 6.3: Calculation Assumptions
 - 6.4: Analysis Results
 - 6.5: Conclusions
- Section 7: Recommendations – Pg. 41
 - 7.1: General
 - 7.1: Research
 - 7.2: Physical Testing
- Section 8: Conclusions – Pg. 45
 - 8.1: General
 - 8.2: Major Findings
 - 8.3: Benchmark Comparisons
 - 8.4: Summary of Conclusions
- Appendix A: Fundamental Engineering Principles – Pg. 49
 - A.1: General
 - A.2: Material Comparison: Axial Compression Strength
 - A.3: Material Comparison: Axial Stiffness
 - A.4: Material Comparison: Maximum Strength/Link Beams
 - A.5: Material Comparison: Span End Conditions
 - A.6: Tall Building Principle: Floor-to-Floor Height
 - A.7: Tall Building Principle: Management of Gravity Load Paths
 - A.8: Tall Building Principle: Lateral System Efficiency
- Appendix B: Interpolation of Results for Shorter Buildings – Pg. 56
 - B.1: General
 - B.2: Comparisons
 - B.3: Summary of Height Studies
- Appendix C: Alternate Systems Studied – Pg. 59
 - C.1: Introduction
 - C.2: Design Methodology
 - C.3: ‘All-Timber’ System Description
 - C.4: Comparison Summary of Proposed and ‘All-Timber’ Systems
- Appendix D: Adaptation for High End Condominiums – Pg. 62
 - D.1: General
 - D.2: Adaptation Requirements
 - D.3: Gravity Framing System Adaptation
 - D.4: Lateral Load Resisting System Adaptation
- Appendix E: List of References – Pg. 63

Acknowledgments

Funding for the Timber Tower Research Project was provided by the Softwood Lumber Board. The Softwood Lumber Board is an industry funded research, promotion and information program for softwood lumber. The purpose of the program is to strengthen the position of softwood lumber in the marketplace, maintain and expand markets for softwood lumber, and develop new uses for softwood lumber within the United States. The research presented appropriately contains study and analysis designed to advance the desirability, use, and product development of softwood lumber. For more information and to contact the Softwood Lumber Board, refer to the following contact information:

Softwood Lumber Board
330 N. Wabash Avenue
Chicago, IL 60611
Phone: 312-321-5131

www.softwoodlumberboard.org

SOM would also like to thank Mr. Steve Lovett & Mr. Cees DeJager at the Softwood Lumber Board for their efforts in coordinating the project.

SOM would also like to thank the following organizations and individuals for reviewing the project and providing useful feedback:

- Anthony Forest Products Co. – Aubra Anthony Jr., Kerlin Drake, Jeff Stefani
- American Wood Council – Brad Douglas, Robert Glowinski
- FPInnovations – Erol Karacabeyli
- Idaho Forest Group – Marc Brinkmeyer
- Structurlam – Bill Downing, Kris Spickler
- Shen Milsom & Wilke, LLC – Erik Ryerson
- The University of Queensland – Jose Torero
- WoodWorks – Cheryl Ciecko, Scott Lockyear
- Dr. Nick Isyumov

Executive Summary

Tall buildings pose a unique challenge to the sustainability movement because they offer both positive and negative environmental impacts. Positive impacts include reducing urban sprawl, promoting alternative transportation, and allowing efficient energy use on a district scale. These benefits come at the cost of emitting more carbon dioxide to produce the materials and to construct the building. A tall building's embodied carbon footprint is significantly higher relative to low-rise buildings on a per square foot basis. This is because the structure is usually responsible for the majority of the building's embodied carbon footprint, and tall buildings require far more structure to support their height. Structural systems that minimize embodied carbon for tall buildings allow the positive environmental aspects of tall buildings to be more pronounced.

Structural engineers currently have four primary materials in which to design buildings: steel, concrete, masonry, and wood. Tall buildings use steel or concrete almost exclusively for two reasons. First, with some limited exceptions, non-combustible materials are required by most building codes for buildings greater than four stories tall. Second, steel and concrete have higher material strengths than masonry and wood, making them a natural choice for tall buildings which require supporting very large loads. Until now, these factors have generally limited wood use to low-rise buildings. Recently, designers from around the world have begun to take advantage of a lesser known quality of wood – it is a carbon sink, the physical result of photosynthesis. This fact, along with the lesser overall energy that is required to produce wood, has encouraged the idea of tall wooden buildings. The wood solution for sustainable tall buildings is attractive, but also requires care from the engineering community since few contemporary precedents exist.

The goal of the Timber Tower Research Project was to develop a structural system for tall buildings that uses mass timber as the main structural material and minimizes the embodied carbon footprint of the building. The structural system research was applied to a prototypical building based on an existing concrete benchmark for comparison. The concrete benchmark building is the Dewitt-Chestnut Apartments; a 395ft tall, 42 story building in Chicago designed by SOM and built in 1966. SOM's solution to the tall wooden building problem is the "Concrete Jointed Timber Frame". This system relies primarily on mass timber for the main structural elements, with supplementary reinforced concrete at the highly stressed locations of the structure: the connecting joints. This system plays to the strengths of both materials and allows the engineer to apply sound tall building engineering fundamentals. The result is believed to be an efficient structure that could compete with reinforced concrete and steel while reducing the carbon footprint by 60 to 75%. Further reductions are possible with an 'All-Timber' scheme, but this scheme was not chosen due to technical complications and increased material costs.

SOM believes that the proposed system is technically feasible from the standpoint of structural engineering, architecture, interior layouts, and building services. Additional research and physical testing is necessary to verify the performance of the structural system. SOM has also developed the system with consideration to constructability, cost, and fire protection. Reviews from experts in these fields and physical testing related to fire is also required before this system can be fully implemented in the market. Lastly, the design community must continue to work creatively with forward thinking municipalities and code officials using the latest in fire engineering and performance based design to make timber buildings a viable alternative for more sustainable tall buildings.

Report Overview

Organization

Three deliverables are associated with the research project: a report (8.5"x11" format), sketches (11"x17" format), and a 3D PDF file of the structure. The deliverables should be read and viewed together for a full understanding of the presented systems. The report is organized as follows:

1. **Introductory Materials.** This section includes the table of contents, acknowledgements, executive summary, and report overview.
2. **Main Body, Sections 1-5.** This is the main body of the report. The proposed systems are discussed from the perspective of individual disciplines (structural, architectural, interiors, building services). Each section discusses the rationale behind the proposed systems, along with alternates. Each subsection references the accompanying sketches that are related to the topics discussed.
3. **Concluding Material, Sections 6-8.** These sections summarize comparisons to the benchmark building along with recommendations for additional work and conclusions.
4. **Appendices.** The appendices cover topics in greater detail than the main body, as well as alternate systems and building types.

Definition of Terms

The following terms are used in the report:

1. **Benchmark Building.** This refers to the Dewitt-Chestnut Apartment Building, currently named Plaza on Dewitt. This building has been used as a benchmark for comparison between a building with a reinforced concrete structure and one with a timber structure.
2. **Prototypical Building.** This refers to the timber building documented in the deliverables. The building is based on the program, floor plan geometry, and number of stories of the Benchmark Building.
3. **Composite Timber Structural System.** This refers to the 'Concrete Jointed Timber Frame' structural system proposed for the Prototype Building. This is a stand-alone structural system that could be applied to buildings of varying geometry and height. This structural system is documented in the context of the Prototypical Building in order to draw comparisons with the Benchmark Building.

Section 1: Project Overview

1.1 Sustainability and Carbon Footprint

Sustainability has become a major issue in building design and construction within the past decade. The primary issue at hand is carbon dioxide emissions associated with the production of energy for use in buildings [1.11, 1.12]. Buildings are responsible for nearly half of all energy consumed in the United States [1.11]. As a result, the design community has rightly focused their attention on reducing the energy consumed in buildings. This has been done by using more energy efficient building services, replacing artificial light with day lighting, and using high performance facades that reduce the heating and cooling needs of the building. These approaches have shown promise and continue to be the focus of the community as can be seen with efforts such as Architecture 2030 Challenge (<http://architecture2030.org/>). This challenge to the design community is to achieve net-zero emissions buildings by the year 2030.

The carbon emissions associated with a building come not only from the energy consumed during the life of the building, but also from the carbon emissions associated with the construction of the building [1.1, 1.2, 1.6, 1.11]. The carbon emissions associated with the construction of the building are referred to as the 'embodied carbon footprint' of the building. The total carbon footprint of the building is the sum of the operational carbon emissions and embodied carbon emissions. The ratio of embodied to operational carbon is typically 10-30% depending on the type of building and lifespan. This ratio is constantly changing as buildings become more efficient. If the 2030 challenge is met, the embodied carbon footprint of the building will be the entire footprint of the building.

The entire carbon cost of a building is a concept that was developed in the 1960's and has been gaining popularity through life cycle assessment (LCA) [1.1, 1.2, 1.4-1.7]. LCA can show that the structure of a building is the largest contributor to embodied carbon of the building. A deeper look reveals that it is the production of materials used in the structure that is the leading contributor to the embodied carbon footprint [1.1, 1.7]. These facts suggest that the structural engineering design is a key factor affecting the embodied carbon footprint of the building.

The embodied carbon of a building structure can be reduced in two ways. First, the engineer can try to design a building which minimizes structural materials. Reducing the amount of structural materials generally reduces cost to the owner and thus a quality structural design already minimizes the materials used. Secondly, the engineer can design a building which uses less carbon intensive materials such as timber.

The least carbon intensive material that engineers have at their disposal is wood. This is true for two fundamental reasons. First, wood is made of carbon that comes from the process of photosynthesis where carbon dioxide is taken in by the tree, stripped of the carbon, and oxygen is released. Wood is approximately 50% carbon by weight. Wood removes carbon from the atmosphere and stores it for the life of the wood, making it a carbon sink. Secondly, the process to produce structural grade wood can take less energy than that for steel or cement for concrete. A main energy requirement for wood is in the drying process [1.8-1.10]. In some cases, the wood is dried by burning forest bio-mass which can be a carbon neutral process. Wood can also be air dried to further reduce the energy required to produce. Thus, the use of wood where possible is an effective way to improve the embodied carbon footprint of a structure.

1.2 The Role of Tall Buildings in Sustainability

Tall buildings are a vital element in any urban setting as they make the best use of limited space. In that regard, they promote urban density which has beneficial sustainability aspects [1.3, 1.4]. Compact cities promote sustainable transportation methods such as walking, cycling, and public transportation. This reduces the carbon dioxide emissions associated with transportation which is the second largest source of total carbon dioxide emissions. Tall buildings also have the ability to be more energy efficient than single family residences through the use of efficient central services and higher overall building volume to surface ratios (shared floors/ceilings, minimal weather exposed surfaces). Lastly, dense cities can take advantage of efficient district heating and cooling systems where multiple buildings are linked to share energy sources.

However, tall buildings come at the cost of higher embodied carbon footprints on a unit area (per square foot) basis. This is primarily due to the additional structural materials needed to support a tall building. The extra material required is often referred to as the 'premium for height' and it comes from two main sources. The first is the length of gravity load paths. Columns in a tall building must hold up the floor they are directly below and also the weight of all floors above them. This requires the columns to be larger and use more material. The second source is the impact of lateral loads such as wind. The dominant behavior in a tall building is the movement of the building related to overturning moment, the torque at the base of a building caused by lateral loads such as seismic movements and wind. The overturning moment increases quickly with height. For example, a 30 story building will need to resist an overturning moment approximately 9 times greater than a 10 story building. The premium for height cannot be avoided, only minimized by the structural design. In terms of sustainability, the 'premium for height' can be thought of in terms of both cost and carbon footprint.

The construction of tall buildings will be difficult to avoid considering the world's population is projected to increase from 7.0 billion people now to 11.0 billion people in 2050 [1.3, 1.12]. More importantly, the number of people living in cities will double in that time from 3.5 billion to 7.0 billion [1.3, 1.12]. Tall buildings will probably be needed in order to house that many people in our cities. The tall buildings constructed to fill that requirement need to be done in sustainable ways to limit the environmental impacts.

1.3 Purpose of the Research Project

The purpose of the research project was to study and develop a conceptual structural system for tall buildings that is as sustainable as possible while remaining cost competitive with contemporary building techniques. The structural system is to be flexible to suit many architectural layouts, not just a single size floor plate, geometry, or height. Understanding that wood is arguably the most sustainable structural material, the system is to consist primarily of wood. Technological advances in wood technology have made this possible with products referred to as 'mass timber'. These products use renewable softwood products that are built up using adhesives. The resulting structural elements behave similar to heavy timber. The advantage is that the material can scale to larger sizes necessary to support the required loads as well as behave like heavy timber in a fire by charring rather than burning.

The conceptual structural system was used to design a prototypical building which was based on an existing benchmark building. This was done in order to develop a reasonable solution and calibrate the results against competing technologies. The material quantities required and carbon footprints are compared to validate the design. The benchmark building chosen was the Dewitt-Chestnut Apartments and is discussed in Section 1.4.

1.4 Research Objectives

The research project had the following objectives:

- Develop a conceptual structural system for tall buildings which utilizes mass timber as the primary structural elements
- Apply the conceptual structural system to a prototypical building which is based on the geometry and program requirements of a benchmark concrete building
- Coordinate the structural systems with the architectural elements, interior layouts, and building services of the Prototypical Building
- Compare the design of the Prototypical Building to the Benchmark Building in terms of material quantities and embodied carbon footprint
- Compare the design of the Prototypical Building to the Benchmark Building in terms of impacts to the designs of other disciplines
- Interpolate the results to building heights of 10-30 stories
- Propose possible construction sequences
- Provide recommendations for additional research and testing

The research effort was focused on the structural system of the building and the impacts it has on the other aspects of the design. Non-structural items such as the design of the exterior wall beyond structural coordination were not part of scope of this project.

The research also includes an initial effort to understand and suggest a way forward related to fire safety strategies but it was understood that formulating a fully engineered solution to address fire was not in the scope of this effort.

Likewise, initial efforts were undertaken to study construction costs for a timber building. While determining material costs is achievable, determining complete construction costs including erection was not in the scope of this effort and will need to be studied further using the resulting structural system and assumed erection sequence. It is also believed that efficiencies in manufacturing and erection of tall, timber buildings will improve rapidly as the industry matures and multiple timber building projects are completed.

1.5 Dewitt-Chestnut Apartment Benchmark: Ref. Sketches G-01, G-02

The Dewitt-Chestnut Apartments, currently known as the Plaza on Dewitt, is located in Chicago, Illinois. The building was designed by SOM and completed in 1966. The floor plan dimensions are 80'-0" by 124'-6". The building has one basement, ground level lobby floor, 41 residential floors, and a rooftop which houses building service equipment and amenity spaces. The height of the building is 395ft at the roof. The parapet of the building extends another 21ft.

The structure of the building is a reinforced concrete flat plate floor with interior gravity columns and a perimeter 'framed tube' to resist wind loads. The framed tube consists of closely spaced columns at 5'-6" on center typically, connected with a moment frame beam. The system behaves as if the perimeter of the building was a solid thin walled concrete tube with punched openings for windows. This system is very efficient and the Dewitt-Chestnut Building was the first building to use the system.

The efficiency of the system is evidenced by the material quantities of the building:

- 0.98 cubic feet of concrete per square foot of area
- 5.9 pounds of rebar reinforcement per square foot of area

This building was chosen as the benchmark for several reasons:

- It is a real building which has been successful and is still marketable
- The lease depths of the floors are consistent with contemporary residential fit-outs
- It is very efficient with structural materials, giving a lower-bound for comparison
- The building geometry is a relatively simple shape, rectilinear and extruded.
- As an SOM design, the data was easily accessible

Section 2: Structural Design

2.1 Structural System Overview

The design of a 42 story timber building must be approached from sound engineering principles in order to be successful. The designer must create a system which plays to the strengths of the materials chosen while minimizing their weaknesses. The designer must also be aware of the forces at work and arrange the structural elements to leverage gravity forces to help resist the lateral forces. These principles are true for the design of any tall building but their importance is amplified when timber is the primary structural material. Tall building engineering concepts are important for the design of tall wooden buildings and Appendix A: Fundamental Engineering Principles includes detailed background information relating to material properties of wood and tall building design principles.

2.2 Structural System Description: Ref. Sketch S-01

Overview

The Concrete Jointed Timber Frame consists of solid mass timber products connected with steel rebar reinforcement through concrete joints. Mass timber products are used for the primary structural elements such as the floors, columns, and shear walls. Steel rebar reinforcement is connected to the primary structural elements by drilling holes in the timber and epoxy bonding reinforcement in the hole. The connection of timber member to timber member is done via lap splicing reinforcement through the concrete joints. The result is a band of concrete at the perimeter of the building and bands of concrete at all wall/floor intersections. Supplementary reinforcement is provided in the concrete perimeter beams to achieve long spans as well as the concrete link beams which couple the behavior of individual wall panels. Additional structural steel elements are used at the joint locations to connect the primary timber members during erection and prior to concreting the joints. The system is approximately 80% timber and 20% concrete by volume for a typical floor. The entire building is approximately 70% timber and 30% concrete by volume when the concrete substructure and foundations are considered.

Gravity Load Resisting System

The floor system consists of solid mass timber CLT or similar panels that span between timber shear walls at the center of the building and the reinforced concrete spandrel beams and timber columns at the perimeter. The system is similar to a concrete flat plate system where the ends of the floor panels are rotationally restrained by the columns and walls through the rebar reinforcement connections. This scheme stiffens the floor which enhances the deflection and vibration characteristics, leading to a more economical floor system. The spandrel beams were designed to resist torsion to deliver the floor panel end moments to the columns. The columns and walls deliver the gravity loads to the stories below and ultimately the foundations.

The roof level that supports building service equipment has been designed as a composite floor system which consists of a solid engineered CLT panel with a composite normal weight concrete topping slab. The concrete topping slab is necessary at this level to distribute large concentrated equipment loads and to enhance the acoustic requirements of the floor. The floor at this level was designed as simply supported.

Lateral Load Resisting System

The lateral load resisting system consists of solid mass timber CLT or similar shear walls. The shear walls are primarily located around the vertical transportation and service core at the center of the building forming a large tube which resists wind in both directions as well as overall building torsion. Supplementary shear walls extend from the central core to the perimeter of the building at the east and west ends of the core. These walls are critical to resist net building uplift due to wind forces on the broad face of the building. The shear walls that extend from the central core reduce in length along the height of the building as the overturning demands from wind decrease. The shear walls are coupled by reinforced concrete link beams to make the entire building act like one large vertically cantilevered beam similar to a traditional tall building system. The link beams must resist large shears and bending moments to couple the walls and are reinforced accordingly. The design approach for this system followed similar strategies that would be applied to a tall concrete building utilizing coupled shear walls.

Acoustic and architectural finishes applied to the floor panels result in 3 inches of additional ceiling sandwich thickness for the Prototypical Building compared to the Benchmark Building. This requires the floor to floor dimension to increase from 8'-9" to 9'-0" in order to maintain the same floor to ceiling height. The additional floor to floor height increases the total height of the Prototypical Building by 10'-6" which results in additional wind loads on the building.

Lobby Level and Substructure System

The building is designed as all concrete from foundations to Level 2 (first floor above the lobby). The increased strength of the concrete shear walls and columns through the lobby allows a reduced shear wall system through this zone. This allows for increased flexibility and openness of the lobby levels. The gravity columns located at the East-West centerline of the building are also transferred to the adjacent columns to improve the entry condition. The ground floor is to be framed with reinforced concrete beams and slabs. Concrete framing was chosen for these levels to resist high construction loads as well as enhance the durability of the building that will be in contact with outside weather.

Foundation System

The foundation system of the Benchmark Building consists of belled caissons bearing on hardpan approximately 75ft below grade. The same foundation type was used for the Prototypical Building. The Prototypical Building is significantly lighter compared to the Benchmark Building thus only 65% of the original foundation elements are required to support the Prototypical Building.

Construction Sequencing Elements

The structural system has been designed so that the Prototypical Building could be constructed similar to a structural steel building with metal deck slabs in terms of erection and sequencing of trades. The vertical column and wall elements are connected to the corresponding vertical elements on the stories above and below with structural steel end fittings. This allows the erection of the timber elements to proceed up the building without immediate concreting of the joints. The formwork for the concrete joints would be supported on the vertical structure so that re-shoring is not required. The lower portions of the spandrel beams were also designed as precast concrete in order to avoid re-shoring of concrete elements.

Quantity Comparisons

The following quantities were determined for the Benchmark and Prototypical Buildings. The reported quantities are the average quantities on a per square foot basis. The foundation quantities have been averaged over the total building area.

Benchmark Building, Take-Off Quantities:

Sub & Superstructure:

Concrete: 0.98 cu.ft/sf

Reinforcement: 5.9 psf

Foundations:

Concrete: 0.14 cu.ft/sf

Reinforcement: 0.1 psf

Prototypical Building, Estimated Quantities:

Sub & Superstructure:

Timber: 0.80 cu.ft/sf

Concrete: 0.25 cu.ft/sf

Reinforcement: 1.7 psf

Structural Steel: 0.3 psf

Foundations:

Concrete: 0.09 cu.ft/sf

Reinforcement: 0.1 psf

The volume of structural materials required for the composite timber Prototypical Building indicates that the structure is efficient. This suggests that high-rise timber buildings could be competitive to reinforced concrete buildings once effective construction methodologies have been established. The construction logistics and erection costs of the proposed composite timber structural system need to be evaluated by industry representatives before any final conclusions about cost competitiveness can be made. Consideration should also be given to the cost of non-structural elements such as finishes and differences in story heights.

2.3 Structural Materials Ref. Sketches S-05, S-06

The following is a breakdown of the different materials used and how they relate to each type of structural element.

Mass Timber Products

The proposed structural system can be designed with mass timber products built up using different species and grades of wood. Potential species include, but are not limited to, Douglas Fir – Larch (DF-L), Hemlock-Fir (HR), Spruce-Pine-Fir (SPF), and Southern Yellow Pine (SYP). The grade chosen is related to the desired performance for the different elements in the structural system such as the floors and the columns. In that respect, it is more useful to categorize the wood material chosen in terms of desired strength and stiffness similar to a machine stress rated (MSR) lumber. The following sections note the material performance targeted for each element in the structural system. Note that wood material with structural properties that are higher or lower than those shown could also be considered with some impact to structural member sizes and material quantities.

The structural elements are designed primarily to use existing mass timber technology. Potential alternates which use less adhesive are also discussed. The mass timber technology used most is cross laminated timber (CLT). CLT is a composite panel that consists of glued, sheets (plies) which alternate in orientation 90 degrees between each sheet. Each sheet is comprised of standard dimensional lumber (i.e., 2" thick). Each ply of lumber has the grain running in the same direction and is glued to the adjacent plies by application of adhesive to the wide faces of the lumber. Standards for CLT are provided in AISI/APA PRG 320 [2.1]. CLT is used for the floor panels and shear walls. Structurally glued laminated members are used for the columns.

Base design using existing mass timber products:

1. Floor Panels. Reference Detail 1 on S-05. The floors are designed as CLT. The choice to use CLT is primarily based upon the need for the floors to be dimensionally stable with respect to changes in humidity. Additionally, the possibility of two-way behavior is useful for vibration control if the connections between panels are adequate. The floor details shown are built up using two 3-ply CLT panels. This approach was used in to increase the amount of wood members with the grain oriented in the primary spanning direction. The floors were sized with a flexural strength design value of 900psi and modulus of elasticity of 1,400ksi.
2. Columns. Reference Detail 2 on S-05. The columns are designed as structurally glued laminated elements. The primary requirements for the columns are high axial strength and stiffness. The columns were designed with an axial design strength of 700psi at the top of the building and 1,400psi at the base. The columns were designed assuming a modulus of elasticity of 1,200ksi to 1,500ksi. The columns can benefit the most from using high strength materials to reduce sizes. MSR wood should be considered for these elements to make the column sizes similar to those in a reinforced concrete building.
3. Shear Walls. Reference Detail 3 on S-05. The walls are also designed as CLT. The walls need dimensional stability along their length which is provided by the CLT build up of alternating ply orientations. The primary demands on the walls are axial compression, in-plane bending, and in-plane shear. Of these three demands, axial compression is the most critical to design. This is because the axial stiffness of the

individual shear walls contributes most to the overall building movements due to wind loads. For this reason, the walls have been built up using multiple 3-ply CLT panels with grains primarily oriented vertically. This also enhances the in-plane bending strength of the walls and has negligible effects on the in-plane shear strength of the walls. The walls were sized with an axial compression strength design value of 1,000psi, shear strength parallel to grain design value of 120 psi, and modulus of elasticity of 1,400ksi. The boundary elements of the walls were designed using an axial compression strength design value of 1,400psi and bending capacity of 1,200 psi.

Alternate designs to reduce adhesive quantities:

1. Floors Panels. Reference Detail 1 on S-05. This alternate would be a variable thickness product but uses a maximum of 5 wood plies. The outer 2 plies on each face are necessary to have characteristics similar to CLT and would be made up of 2in material (1 3/8" per ply). The central ply would be the structural core and would scale to meet the thickness requirements of the floors. For instance, a design that required a 10" thick panel would have (4) 1 3/8" plies and a 5in core. The total thickness would be 10" and save 2 layers of adhesive. This would reduce the adhesive needed for a typical CLT build up by 33%.
2. Columns. Reference Detail 2 on S-05. This alternate is a structurally glued heavy timber column which saves adhesives. Take a 24x24" column for example. The column built up with 2x12s results in 4338 square inches of adhesive per column foot of length. The same column could be built up with 4-12x12s and requires only 540 square inches of adhesive per column foot, reducing the adhesive by 87%. Note that the design strength and stiffness of the heavy timber will be less than a smaller member. The heavy timber column may need to be as much as 35% larger in dimension to achieve the same strength as the column built up using smaller members. In this case, the adhesives would only be reduced by 65%. Lastly, the larger heavy timber column required toward the bottom of the building may be undesirable.
3. Shear Walls. Reference Detail 3 on S-05. This alternate is a structurally glued heavy timber shear wall with nominal 2in material running horizontal on the outer surfaces. The outer material is necessary for dimensional stability. The walls are typically controlled by stiffness requirements which are not significantly impacted by the use of heavy timbers. The adhesives used in the shear walls could be reduced by 65% by using these types of walls instead of CLT walls.

Concrete

The concrete used in the design was normal weight, normal strength (6,000psi or less). Some care will likely be needed in the concrete mix design. First, concrete shrinkage needs to be low so that crack widths at the concrete-timber interfaces are small. This suggests a low water to cement ratio in the design or perhaps even shrinkage compensating admixtures. Second, the concrete will need to have good flowability and compacting characteristics as access for vibration will be limited at the wall joints. This suggests that plastisizers will be needed for the mix or that it be designed as self consolidating / self compacting concrete. Mockups and testing will determine the actual concrete requirements.

Steel Reinforcement

Standard grade 60ksi reinforcement was used. Generally, #4 bars are used to connect the walls and floors through the concrete joints. These small bars are used to limit stress concentrations in the wood. The use of small bars also limits the development lengths of the bars so that they can be developed within the concrete joint dimensions. The longitudinal reinforcing in the spandrel and link beams is larger due to the strength demands. #5 bars are used typically with bars as large as #7s for select critically stressed link beams. Higher grades of steel should be considered in these areas to reduce potential congestion and increase construction speed.

Structural Steel

Standard grade 50ksi structural steel is used for the steel erection elements and for the net uplift tension ties embedded in the timber members.

2.4 Gravity Resisting System: Ref. Sketches S-03, S-05

Material Economy

The design of the floor system is perhaps the most crucial aspect of the design because the floors are responsible for approximately 70% of all material used on a typical story. An economical floor system is necessary for the overall building structure to be economical. The Benchmark Building floor system consists of a 7½” thick reinforced concrete flat plate which is similar to common current designs which are often 8” thick. The design of the floor framing for the Prototypical Building must use a similar amount of material in order to be cost competitive with a concrete structure.

Span Length vs. Interior Columns

In concrete building design, the span of an 8” thick flat plate system is often limited to 24ft in any direction to control deflections and keep the reinforcing requirements economical. This causes some complications for an apartment building because the lease depth (distance from central core to perimeter) for a marketable interior layout is generally 27-29ft. This problem is usually solved in a concrete building by introducing interior columns inside the units to break up the spans. These columns can be located on partition lines to minimize the impacts to units.

The interior column strategy that is acceptable for concrete buildings has been determined to be undesirable for the Prototypical Building for three reasons:

1. Interior columns or walls take gravity loads away from the primary shear wall core at the center of the building. This increases the net uplift due to wind which is the controlling design condition for the lateral load resisting system.
2. Interior isolated columns are most advantageous when two-way spanning behavior is available. Two-way spanning behavior of timber panels is difficult to achieve at a strength level due to the resulting connection demands between panels.
3. Interior columns or walls are not consistent with a fire resistance strategy of the structure of using fewer, bigger vertical members which have a higher natural fire resistance. This strategy needs to be verified by fire engineering study.

Thus, the preferred solution is to design the floors to span from the core to the perimeter. This design follows the fundamental engineering principles discussed in Appendix A.

Long Span Strategies: End Rotation Restraint

In a concrete building, a long span floor would need to take advantage of the monolithic construction with the vertical elements. The monolithic construction allows the floors to be rigidly connected to the core walls and perimeter columns. These rigid moment connections provide rotational end restraint to the floor which reduces the peak bending moment demands and stiffens the floors which reduces deflections and vibrations. The end result is a thinner, more economical floor section.

The same logic that would be applied to a concrete building has been applied to the floor framing of the Prototypical Building. The connection strategy of concrete joints gives the designer the opportunity to use thinner timber floor panels to achieve the desired strength and deflection and vibration behaviors. Reference details 4 and 7 of sketch S-05; reinforcement connected in the

timber floor panels is similar to the top bars that would be provided in a concrete slab. In addition to reinforcement which provides diaphragm continuity and possibly a horizontal force couple to restrain rotation, a 12" long concrete corbel has been provided to support the floors. This corbel serves two main purposes. First, it provides additional rotational restraint through a vertical force couple. The force couple consists of bearing on the front edge of the corbel and embedded uplift anchor restraint on the ends of the panel. Second, the corbel may provide passive fire protection of the floor panel bearing zone and moment connection.

Floors that are controlled by deflections or vibrations can be reduced in thickness by approximately 25-35% if end fixity is considered. Considering that the floors require about 70% of the total building materials, the effect of end rotation restraint can reduce the total building materials by 20-25%. To put these savings in perspective, the material saved is approximately equivalent to all of the material used for the columns and walls in the building.

In summary, the proposed system for the Prototypical Building is an 8" thick solid timber floor which utilizes end rotation restraint. The behavior of the floor's connection to the concrete joints and vertical members is critical to the design and therefore must be researched further including physical testing of the connection for both structural and fire performance.

Long Span Strategies: Simple Span

If end rotation restraint is not possible or desired, the floor can be designed assuming pinned end connections. This requires the moment of inertia of the floor to be 3 to 5 times larger than an end restrained floor, or a flat floor panel for the Prototypical Building which is approximately 12½". This would not currently be cost competitive with concrete. Alternatively, a ribbed panel system could be used to add depth to the floor with less material. This approach results in a 14" deep system that still requires 15% more material than the end restrained system with a flat floor panel. The other major implication of the 14" deep ribbed system relative to the 8" flat floor system is the impact to the overall building height:

1. The floor-to-floor height of the building must be increased by 6" per floor to achieve the same floor-to-ceiling height of the flat restrained system. The results in 6"x42 stories = 21ft of extra building height.
2. The new building height increases the wind load on the building without adding much gravity load. The base overturning moment increases by approximately 10% which increases the net uplift by nearly 20%.
3. Additional non-structural building materials are required. The most expensive is likely to be an extra 8,400 square feet of exterior cladding.

Thus it can be seen from comparing the total material usage and impact to building height that the most economical solution is to span from the core to the perimeter and to provide end restraint to the floor system.

Column Spacing, End Restraint and Spandrel Design

The location of columns along the perimeter of the building is generally dictated by the demising wall layout for the interior design. This sets the desired column spacing at approximately 24ft on center. This column spacing requires the spandrel beams to be robust in order to both support the floor load between columns and provide end restraint to the floor system. A concrete spandrel beam is a better candidate than a timber or steel spandrel due to the limited strength of

timber beams in torsion and the connection and fireproofing complexities associated with a steel tube spandrel.

The spandrel beams are responsible for approximately 65% of the concrete used on a typical floor and over half of the total concrete in the Prototypical Building. This material requirement could have been reduced by adding columns at the perimeter. When determining the perimeter column layout, the following were considered:

1. The large column spacing increases architectural flexibility and therefore marketability for the client.
2. The large column spacing results in fewer relatively larger columns which may be preferable in a fire.
3. The large column spacing results in more concrete and reinforcement which increases cost and carbon footprint.

It is believed that the benefits of items 1 and 2 are greater than the additional costs of item 3 so the wider larger column spacing was used in analysis and design.

Floor Vibration Performance







The CLT floors are governed by vibrations. The natural frequency of the floors is in the range of 6.5 to 8.5hz depending on the modeling and structural behavior assumptions made. The total mass of the floor is similar to a steel framed floor with lightweight concrete metal deck slabs. This is because of the mass for acoustic treatments and expected fit-out loads. AISC Design Guide 11 [2.2] was therefore used to evaluate the floors instead of the method provided in the US CLT Handbook [2.3] which is intended for floor systems with a natural frequency above 9Hz. New vibration criteria may need to be developed to adequately address the system proposed. Two vibration criteria were checked using the velocity based method of AISC Design Guide 11. The floors satisfy the following two criteria:

1. Living Areas: 16,000 micro-in/sec w/ moderate walking pace
2. Sleeping Areas: 8,000 micro-in/sec w/ slow walking pace

Alternative Designs & Comparisons

As discussed, the design documented in this report attempts to make maximum use of end restraint from the shear walls and perimeter columns. The end connection details presented were developed using basic engineering principles but have not been tested or verified for this application. Depending on the actual end restraint provided to the timber floors, the stiffness of the floors may need to be increased and, because of cost concerns, this needs to be done with a minimum addition of timber to the structure. For this reason, ribbed planks may be appropriate if further research indicates that the planks must be thicker than 8 inches.

Figure 2.1 below depicts 6 potential floor framing schemes with two variables: slab type (flat versus ribbed) and end fixity conditions (simple support, fully fixed with columns and walls, and partially fixed where only 50% of the end moments of the fully fixed scheme are developed). The results shown are the equivalent material slab thickness, the change in timber quantities (in cu.ft/sf), and percentage change in total timber materials for the building. Note that costs associated with the manufacturing complexities of ribbed panels or epoxy connected reinforcing are not captured by this comparison. It is thought that the costs noted will be secondary to the overall material used.

#	Floor Type	End Support Condition	Beam Diagram	Equivalent Thickness [in]	Quantity Δ [ft ³ /ft ²]	% Change to Total Timber
1	Flat Panel	Simple Sup.		12.5	0.30	38
2	Flat Panel	Partially Fixed		9.6	0.11	14
3	Flat Panel	Fully Fixed		8.0	Baseline	-
4	Ribbed Panel	Simple Sup.		9.5	0.10	13
5	Ribbed Panel	Partially Fixed		8.1	0.01	1
6	Ribbed Panel	Fully Fixed		7.3	-0.05	-6

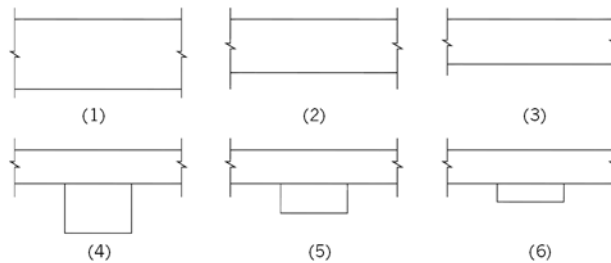

Figure 2-1, Alternate Framing Systems

Floor Framing Strategy within Core

The floor framing within the core consists of solid timber floor panels supported on laminated timber beams. The beams within the core have the ability to be deeper without impacting the floor-to-floor height and do not span as far as the typical floor system. This allows for most of these areas to be designed as simply supported mass timber floors and beams. The floor areas inside the core which still require end fixity are the main East-West and North-South corridors. The floors in these areas are designed with end moment connections to match the lease span panels on the opposite sides of the link beams. This is done so that torsion is not applied to the link beams which are already highly stressed in shear.

The elevator shafts are framed using steel divider beams as they would be in any steel or concrete building. The back and sides of the elevator shafts are also bound by concrete beams at the floor lines (the back of the concrete joints that connect the walls & columns). These concrete zones could have cast-in plates or post-installed anchors to allow the elevator contractor to use standard connections for the cab and counterweight guide rails back to the base structure.

Vertical Structure Gravity Shortening

The columns and walls will shorten due to gravity compression forces. The total shortening is due to short-term elastic loads (all types of structures), long-term creep under sustained loads (concrete and wood structures), and shrinkage (concrete and wood structures). Vertical element shortening becomes a problem when there is a difference between adjacent members which makes the floor unlevel. This phenomenon is referred to as 'differential shortening' and typically occurs between gravity only resisting columns and lateral load resisting systems. Construction methods to partially compensate for shortening have been developed for high-rise steel and concrete structures. Similar methods will need to be developed for high-rise timber structures.

A primary concern for concrete and wood structures is the long term differential shortening due to creep. The estimated long term differential shortening for the 42 story Prototypical Building is 3.2" assuming a creep factor of 1.5 times the elastic shortening for structural glued laminated timber. This amount of differential shortening is approximately 50% higher than what would be expected for a reinforced concrete building of this height.

2.5 Lateral Load Resisting System: Ref. Sketches S-03, S-04, S-06

Key Design Issues

Choosing a lateral load resisting system for a tall building requires special attention to three primary issues listed below. Additional information on these topics is included in Appendix A.

1. System strength. The system as a whole and each individual component must be strong enough to resist the necessary loads. In tall buildings using a core wall lateral system, the most difficult elements to design are often the link beams which couple the movements of individual wall panels.
2. System stiffness. The system must be stiff enough so that cladding and elevator systems are serviceable. Steel structures are more commonly controlled by system stiffness compared to concrete structures.
3. Net uplift due to lateral loads. Net uplift occurs when the lateral load overturning forces overcome the gravity dead load forces of the building. This causes the building to lift up and places the vertical elements in tension. Net uplift is further increased in seismic zones where vertical seismic loads also oppose the gravity dead load of the building. Net uplift is more avoidable in a concrete building due to additional material weight. Tension is more difficult to design for if it occurs as members in tension are difficult to design and construct.

Each of these issues as it related to the Prototypical Building lateral load resisting system is addressed in the following sections

System Choice

A coupled shear wall system was chosen to resist lateral loads for the Prototypical Building. This system was chosen because it is consistent with available timber technology such as CLT shear walls. Other systems were such as a perimeter moment frame, dual system, or a core and outrigger were considered. The coupled shear wall system appeared to be the most economical since the system is very stiff and the technology is available. Therefore, the shear wall system was chosen over the others.

System Strength

As previously noted, the critically stressed members in the lateral load resisting system are the link beams. The maximum shear these members must resist is 120kips in a space of 18" deep by 16" wide. This shear is approximately 80% of the allowable code shear by ACI 318 [2.4] and thus achievable. For reference, the maximum shear that would be able to be carried by the same size timber beam is roughly 50kips. Therefore, the system would not be designable with timber beams and a different layout of structural members or a large increase in wall thickness and link beam width would be necessary.

The design of the wall panels is governed by the boundary elements at the ends of the walls which must resist the concentrated bending moments at the ends of the link beams. These zones of the wall utilize structurally select wood and increased vertical reinforcement to resist the moments.

System Stiffness

The stiffness of the system is governed by global cantilever bending type behavior. Analysis shows that the maximum tip displacement due to a 50-year return period (service) wind is $H/600$ or about 8 inches at the top of the building. This is within the $H/400$ to $H/1000$ range typically experienced in steel and concrete buildings. It should be noted that the aspect ratio of the lateral load resisting system is approximately 5, which is quite stocky when compared to a concrete shear wall structure. This is due to the ratio of elastic stiffnesses between concrete and wood. For reference: 5,000psi concrete has an elastic modulus of 4,300ksi and a common elastic modulus for wood is 1,400ksi. Concrete is approximately 3 times stiffer in axial compression compared to wood. The lateral load resisting system for a timber building is best constructed similar to a concrete structure but requires additional geometric stiffness compared to a concrete structure in order to overcome the lower material stiffness of wood.

Net Uplift Due to Wind

Because wood is a light material, net uplift is a major issue for the design of tall wooden buildings. Consider the following statistics which highlight the issue:

Expected Total Density of Building (Total Weight / Total Volume).

- Density of the Benchmark Building: 21 lb/ft³
- Density of the Prototypical Building: 10 lb/ft³

Expected Dead-Weight Density of Building (Dead Weight / Total Volume).

- Density of the Benchmark Building: 18 lb/ft³
- Density of the Prototypical Building: 7 lb/ft³

For reference, the density of balsa wood is approximately 8 lb/ft³.

It is now important to highlight a secondary benefit of the concrete joints: ballast. The concrete joints make up just 20% of the structural materials by volume on a typical floor yet they account for 55% of the total dead load per floor.

The above suggests that tall wooden buildings are at a disadvantage in resisting net uplift. Design strategies need to be implemented in order to minimize net uplift and reliably transfer any tension forces to the foundations.

Strategy to Mitigate Net Uplift & Design in Prototypical Building

The proposed structural system mitigates net uplift in the following ways:

1. The floors span from the core to the perimeter and avoid interior columns which would take gravity loads away from the lateral system.
2. The effective width of the core is increased by eliminating unnecessary vertical structure in the middle of the building, including structural walls located in front of elevator shafts. The remaining structure is minimized to move gravity loads to the extremities of the building for increased stability.
3. The spandrel beams located at the end of the core wall system (at the extended North/South walls) act like moment frame beams to engage adjacent columns. These beams are designed to transfer gravity loads to the lateral system and wind loads to the columns.
4. The concrete joints provide ballast to hold the building down.

All of these strategies combined could not eliminate net uplift in the building which still exists from the foundations to level 6. The peak ultimate uplift tension is approximately 1,000kips and this occurs at the four pilaster columns which connect directly to the shear wall system.

The Prototypical Building was designed for this uplift force rather than introducing additional measures such as a dual system on the short faces of the building or outrigger elements which would likely be more costly. Instead, the four columns at the ends of the North-South shear walls which experience uplift would be constructed with continuous vertical reinforcing plates laminated within the columns. The steel plates would be field bolted through the joints to transfer load from column to column between the levels. The uplift through the plaza and basement levels would be resisted with mechanically spliced vertical reinforcement in the concrete columns.

Lateral Load Path and Connections

This subsection discusses the lateral load resisting system in detail, following the load path by starting with the wind against the exterior walls of the building through the structure and down to the foundations.

1. Wind load to Diaphragms: Wind loads applied to the façade transfer to concrete spandrel beams through the façade to beam connections. The wind loads are then transferred to the solid timber diaphragms by either bearing (windward side) or tension in the rebar which connects the solid timber floors and concrete spandrel beams (leeward side).
2. Diaphragms: The strength of the diaphragms is limited by shear in the connections between individual panels. The design of these connections can be varied to meet the specific demands throughout the building. The typical diaphragm connection required for the Prototypical Building was determined to be 5/8" diameter lag bolts spaced at 12" on center. The diaphragm connections could also be designed with self-tapping screws if they are found to be more advantageous. The diaphragm is equivalent to a concrete diaphragm stiffness which is approximately 2 1/2" thick. As such, the diaphragms behave much more like rigid than flexible diaphragms.
3. Diaphragms to collector elements: The concrete joints form very robust collector elements at the perimeter of the building and along shear walls. The restrained floor connection provides distributed connections along each timber floor and concrete beam interface. Load is transferred along these interfaces in bearing,

- tension, and shear friction. The reinforcement required for end restraint of the floors is far in excess of the collector element connection requirements.
4. Collectors, concrete wall joints: The primary collector elements are also the horizontal concrete joints in the walls. Wind load from the diaphragm is transferred to the shear walls the same way story shear is transferred from level to level. This connection uses shear friction at the interface of the concrete and timber. Most shear walls in the building are always in compression due to gravity load and need very little reinforcing to transfer shear through the concrete joints. The typical requirement for shear friction is exceeded by steel used to resist temperature and shrinkage strains in the concrete: 2-#4 bars at 18" on center. The walls with high shear may require twice that value along with shear keys in the concrete.
 5. Isolated shear wall in-plane shear: Shear is resisted by the wall section similar to any CLT/mass-timber shear wall system.
 6. Isolated shear wall in-plane bending: The local in-plane wall bending does not overcome gravity loads on the element. In-plane bending of a wall is transferred from story to story by bearing through the concrete joints. The joints stronger than necessary for the required loads.
 7. Isolated to coupled wall behavior via link beams: The link beams force the shear wall system to act like one very large 'H' shaped cantilevered beam by restraining relative wall movements. This beam restraint results in vertical shear at the link beam which is transferred through the wall boundary elements located at the ends of each individual wall panel. The boundary elements put shear in the link beams through direct bearing. The boundary elements must also resist the resulting end moments in the link beams. End moments are transferred by #4 vertical reinforcement epoxy connected to the boundary element and developed in the concrete beam/joint. The design of the boundary elements varies based on the loads in the link beams. In some cases, higher strength (better grade) woods will be used in the boundary elements to avoid crushing the wood prior to the link beam yielding in flexure.
 8. Global building behavior: Once the loads are transferred to the walls and individual walls coupled, the building behaves in global overturning flexure as is typical and desired in tall buildings. The global flexure results in axial forces in individual shear walls. The total axial compression due to gravity plus wind results in walls that are approximately 12 inches thick for the primary walls. Where it exists, net global uplift is resisted by steel plates laminated in the vertical elements and bolted together at floor joints as shown in details 3 and 4 of sketch S-06. Shear forces at locations of net uplift must be resisted with discrete structural steel connectors because shear friction type behavior may be unreliable if horizontal cracks develop due to the tension. Fortunately the areas of the lateral system which experience net uplift are minimal.

Design for Wall Penetrations

The number of penetrations in the walls is limited. Some isolated penetrations will be required for plumbing. Where practical, penetrations will be routed through the concrete connecting bands in the shear walls, away from the boundary elements. The concrete bands can be reinforced as needed to allow for the penetrations. Additional penetrations may be allowed in the timber portion of the walls without reinforcement based on stress levels. These penetrations would need to be considered on a case by case basis.

Wind Excitation Studies

Wind excitation is often the result of vortex shedding. Vortices are shed in a harmonic fashion applying alternating cross-wind (lift) forces to the building. A building is most prone to wind excitation when the natural frequency of the wind vortices matches the natural frequency of the structure and resonant behavior occurs. The designer can make some judgment about the potential for wind excitation by comparing these natural frequencies. Because the building frequencies are low it is more convenient to use natural periods, the inverse of natural frequency.

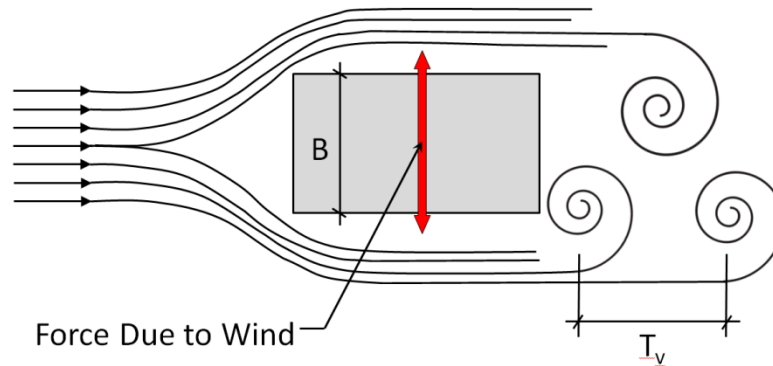

Figure 2-2

The fundamental vibration modes of the structure were determined with a three dimensional finite element analysis of the entire building. The analysis considered service level cracking of the reinforced concrete link beams. The mass of the building in the analysis was 100% of the design dead load and 15% of the design live load (expected residential live loads based on ASCE 7 commentary). The fundamental vibration modes were determined to be:

- T1 = 3.6 seconds (translation in the North-South direction)
- T2 = 3.2 seconds (translation in the East-West direction)
- T3 = 2.8 seconds (twisting about the vertical axis)

Higher order vibration modes are all below 1.0 second and need not be considered.

A building of this proportion with these estimated building periods is not as susceptible to resonant wind movements at the commonly occurring wind speeds that may be encountered during its service life. Moreover, the vibration modes could be 'tuned' if analysis showed that building motions would be unacceptable. The building stiffness could be increased by 50% and the fundamental period reduced to 3.0 seconds by enhancing the stiffness of critical members in the lateral system. Note that these increases in building stiffness require an additional 10% of total building material which suggests that the proposed structural system can be designed to accommodate a reasonable amount of wind excitation without adding excessive materials and associated cost.

2.6 Foundation System: Ref. Sketch S-02

Foundation systems vary greatly depending on project location. Chicago has soft clays near the surface so deep foundations are generally required for tall buildings. The foundations for the Benchmark Building consist of belled caissons bearing on hardpan approximately 75ft below ground. The same foundation system was selected for the Prototypical Building.

Gravity loads and control of settlement generally govern the design of foundations for tall buildings. The foundation gravity loads for the Prototypical Building are approximately 55% of those of the Benchmark Building. The foundations for the Prototypical Building would actually require 65% of the foundation material used for Benchmark Building, as some caissons are governed by wind load combinations. This is another effect of the light weight structure.

Net uplift was discussed in section 2.5 and is a major consideration in the design of foundations. Where possible, tension piles/caissons or soil/rock anchors can be used to resist uplift. Clearly, if underground obstructions preclude the use of foundation systems that can resist uplift, a lightweight structural system such as timber may not be viable.

Foundation uplift addressed in the Prototypical Building in two ways. First, grade beams that connect the caissons are provided to distribute the uplift load to multiple caissons. This allows any remaining gravity loads in the columns adjacent to the core to counteract the uplift. Second, continuous vertical reinforcing is provided in the caisson shafts at lower depth than would be required if no uplift occurred.

2.7 Structural Considerations Related to Fire:

Perhaps more than any other area, design for fire in a tall timber building poses challenges technically and regulatory. The focus of this report is on the technical and not the regulatory challenges. In that regard, there already exist fire strategies, research, and fire engineering methodologies which can be used and are being used in other areas of the world. This along with performance based design allowed by many codes has resulted in the tall timber buildings which are beginning to be built throughout the world. To realize tall timber buildings in the United States, building codes and code officials along with other industry participants including the insurance industry will have to embrace tall timber design. The best opportunity to develop a tall timber building in the United States may initially be to work with forward thinking code bodies, building and other officials, that are comfortable with performance based design for fire and/or to receive code variances for special applications.

Research on fire design in this study is organized to consider the following questions: What is allowed by current building codes? What is required to satisfy those codes? How is performance-based design and fire engineering currently used, and what are the opportunities for these approaches in tall, timber structures? Which principles related to good practice in fire design have been included in the Prototypical Building?

Current codes

Section 3.2 provides a building code overview which notes that current codes, as is well known, do not allow for tall timber buildings (over 65 ft) as they require the structural system to be “non-combustible.” Codes address shorter, wood buildings by providing minimum wood member sizes required in order to be considered heavy timber. Chapter 16 of the NDS [2.5] also provides a methodology to calculate the fire resistance of exposed wood members. This method can be used to calculate the fire resistance of members for up to 2hrs. This duration is less than the fire ratings listed in Section 3.2 for some elements and was therefore not studied further for the proposed system.

Section 3.2 lists required fire ratings for a tall, residential building consisting of non-combustible material for the various building elements including columns, walls, beams, girders, trusses and walls. While this would imply that providing rated assemblies equal to the code may suggest a path forward using current codes, this approach may be flawed because wood is combustible. The code fire ratings have been developed based on the idea that the structure needs to remain safe and avoid progressive collapse for an amount of time related to complete burn-out of the fuel load. Because a timber structure is combustible and can itself become part of the fuel load, new fire ratings are required which take into account the interaction between the typical fuel load (the contents) and the structure itself. This leads to performance based design which focuses on meeting the “intent” of the code rather than the prescriptive requirements.

Performance Based Design

Because a tall timber building cannot comply within the current United States prescriptive code framework, the intent of the code must be understood and translated to equivalent, suitable requirements. The intent of the code typically requires that the fire design focuses on the safety of occupants and firefighters and minimizes the chance of progressive collapse or any other major failure that compromises the integrity of the structure. This is achieved by determining the time required for full consumption of all flammable materials and providing vertical separation for that period of time and horizontal separations required for egress from a particular floor (assuming failure of the horizontal separations don't lead to failure of any vertical separations).

The concept of fire ratings may still exist but with new consideration given to the fuel load because the structure is combustible. Some fire design approaches are to prevent the structure from participating in the fire by 1) protecting it with non-combustible material, 2) preventing ignition under all possible fire conditions, or 3) designing it so the members will self-extinguish and remain fully functional after charring. If this approach is adopted, the building may perform similar to a structure that is non-combustible.

Items of importance for performance-based fire design include the general layout of the floor plans, compartmentalization and containment of fires within one unit, and heat feedback between the structure and the contents. A number of tests and studies will be required 1) to verify that timber elements will self-extinguish, 2) to establish exposure time for the timber elements, and 3) to verify there are no scale factors. These tests and studies include flammability tests, analytical modeling, and a full scale test of one of the larger units.

Proposed connections, both structural and façade to structure conditions, will also have to be tested to determine whether or not change in stiffness due to temperature results in deflections that can open up gaps or that jeopardize vertical separations. Local effects also require testing and further study for performance in a fire. These include studying the distance from the wood surface of reinforcing steel connectors as it relates to possible delamination of timber elements and modeling thermal bridges created by the concrete joints and/or embedded steel elements within the connections.

Fire Design Principles

In addition to the above, a number of principles related to fire design included in the Prototypical Building should be considered and require further study. These include the following:

1. The structure should have some level of passive resistance where practical.
2. Consideration should be given to the condition of the structure after a fire.
3. Timber elements should be simple shapes with high volume to surface ratios to limit charring surfaces and heat feedback potential. Square columns are preferred to rectangular columns.
4. A solid floor system is preferable to one with ribs.
5. Fewer vertical structural elements lead to larger elements which are more efficient at resisting fire.
6. Penetrations through timber walls should be avoided.
7. Standard charring rates such as an average rate of 1.5"/hr should not be used for final design. Rather, an analysis of the building under potential fire scenarios should be considered in sizing of the members.
8. Fire 'burn out' time should be considered in developing fire assemblies.
9. Fire progression: To meet the intent of the code, fire cannot be allowed to jump between floors up the height of the building.
10. Protecting the bottom surface of the CLT may not be required assuming it self-extinguishes.
11. Treatments required for acoustic separation may also provide fire separation.

2.8 Construction Considerations: Ref. Sketch S-07, S-08

Overview

While not directly related to the technical research presented in the report, construction considerations including cost competitiveness and technology will play a large part in determining the success of timber as a structural material for use in tall buildings. The construction industry which exists today that is focused on manufacturing, fabricating, and constructing tall buildings using structural steel and reinforced concrete is mature and has developed and evolved over many years. A similar industrial development needs to occur relating to specific requirements of constructing a tall building made of timber. Logistics including procuring, shipping, handling, scheduling, and managing the construction process will be different in some cases for a timber structure compared to steel and concrete.

Total construction cost relates to schedule, material, labor, tolerances, and required equipment. Each of these elements needs to be developed and refined to result in a cost competitive project. There is no question that much of the knowledge and expertise in the construction industry is transferable between materials. But efficiencies will need to be created for the unique aspects of tall timber building construction.

Most important is to engage the current industry with the advantages of tall timber buildings and solicit feedback from the industry to tailor designs which are most economic to manufacture, fabricate, and construct. The focus of this report in that regard is to propose a possible erection sequence specific to the Prototypical Building and solicit input from the construction industry.

Potential Construction Sequence

One potential construction sequence is similar to that of a steel building with composite metal deck slabs or a precast concrete structure with a cast-in-place topping slab. The primary structure is built and controls the overall pace of construction. The secondary trades follow behind to avoid space conflict between operations and unions. For a steel building, the steel structure is erected with metal deck installed as fall protection. The 'wet trades' follow behind with casting the concrete topping for the composite metal deck slabs several stories below the steel erection. Façade and finish trades follow. This process effectively creates a vertical assembly line.

The construction sequence for the Prototypical Building follows the same logic with the timber members being the primary structure that leads the construction and the cast-in-place concrete joints being the follow up trade below. Similar erection equipment and layouts to those used for typical high-rise buildings are anticipated.

Detail of Potential Construction Sequence

The following construction sequence applies to the typical floors; the lower concrete floors are expected to follow a typical concrete sequence.

1. Vertical Elements. Erect one story long timber columns and individual wall panels above floor below. The columns and wall panels have steel fittings at their ends which connect to steel fittings in the members below. The steel fittings are located at the reinforced concrete joints at the floors. The vertical elements are set and plumbed similar to a precast concrete column or wall. All steel connections are to be field bolted. Field welding is not required in the proposed system.
2. Floor Panel Support. The floor panels will be temporarily supported on a precast concrete beam at the perimeter and formwork at the walls. The walls will be shipped to the site with the formwork attached; the precast beams will be set one at a time, prior to floor panel erection. The precast beams span between perimeter columns and have steel fittings cast at their ends which bolt to the tops of the columns.
3. Floor Panel Setting. The floor panels are then set on the precast spandrel beam and formwork at the core. Discrete structural steel diaphragm connections are made to the wall and column steel fittings for construction stability. These discrete elements also form the spacer columns used to set the next level of vertical elements. Panels are fastened to one another as each new panel is set, forming a diaphragm.
4. Stability of the floor. Once all floor elements are set and connected, the floor is stable. Lateral stability is provided by individual wall elements as link beams are not yet in place.
5. Vertical Progression. The timber construction continues vertically with steps 1-4 without the need for concrete joints. Analysis of the temporary conditions will need to be performed to determine how many floors can be constructed prior to the link beams being completed and reaching strength.
6. Reinforcement placement. Most steel reinforcement will be attached in the shop. The exception is the splices that are required in the spandrel beams and the reinforcement of the link beams. This reinforcement will be placed after the timber has progressed to higher levels. Reinforcement placement strategies will need to be developed to address reduced clearances because of the timber elements already in place. Mechanical couplers may be used for some elements.
7. Concrete placement. Concreting the joints and finishing the horizontal surfaces is the final structural operation at each typical floor. Each floor requires approximately 50 cubic yards or 6 concrete truck loads. For reference, the Benchmark Building required approximately 45 concrete truck loads per floor.
8. Removal of formwork. The only formwork used is the formwork located at the shear wall cores for the joints and link beams and at the exterior face of the spandrel beams. The timing of form removal will be determined by analysis and experience. Note that unlike a concrete building, there is no need to shore and re-shore the concrete elements for the proposed system. Formwork would be designed to be reused higher up in the building.

Section 3: Architectural Design

3.1 Architectural Design Overview

Architectural Design Approach

The Architectural design is for a 42 story residential building located within the Streeterville Neighborhood of the City of Chicago. The Dewitt-Chestnut building, completed in 1966 and designed by Skidmore, Owings and Merrill, LLP is used as a benchmark in which the current design aims to match the existing program of unit types, layouts and quantities. The design has been modified to reflect current market rate rental apartment requirements as well as current codes, standards and best practices. The approach is to design the existing building replacing the original concrete framed tube structural system with a timber system. Special attention is paid to the modifications of commonly used systems and assemblies to allow for the use of timber without impacting the users or occupants of the building. These include acoustics, fire protection, moisture protection, and others.

3.2 Building Code Overview Ref. Sketch A-10

Prescriptive Design

Within the City of Chicago, buildings are required to follow the Municipal Code of Chicago [3.1] and the Chicago Zoning Ordinance and Land Use Ordinance. Similar to the International Building Code [3.2], the allowable height and area are restricted in buildings utilizing heavy timber construction. The Chicago Building Code classifies heavy timber construction as type III-A and identifies minimum thickness for member sizes which can be reduced with the use of an approved automatic sprinkler system. IBC classifies heavy timber as Type IV and provides similar requirements. The use of heavy timber can fall within other types of construction however the primary construction type for comparison in this instance is Type IV (IBC) and III-A (CBC). It should also be noted that the use of Cross Laminated Timber will not be specifically identified within IBC until the 2015 version as noted within the 2013 Cross-Laminated Timber Handbook. For purposes of this analysis however, CLT panels are assumed to fall within the sections identified as “Heavy Timber” but could change based on the IBC 2015.

To construct a 42 story building that exceeds the height allowed in heavy timber construction, the building would have to be categorized as Type IA (IBC) / Type I-A (CBC) both of which require the structural system to be “Non-Combustible.” While this is not possible with timber, the fire resistance requirements of individual elements and types of construction in Type IA could be followed. This can be achieved through a number of strategies including fire resistive coatings or cladding. The fire-resistive rating requirements identified below are noted on the plan diagram on Sheet A-10.

For Type I-A (CBC Table 13-60-100) construction, the major structural elements identified within the code that require fire resistance ratings include:

- Interior Bearing Wall: 4 Hours (3 Hours per IBC Table 601)
- Exterior Columns: 4 Hours (3 Hours per IBC Table 601)
- Columns: 4 Hours (3 Hours per IBC Table 601)

- Beams, Girders & Trusses: 3 Hours (2 Hours per IBC Table 601)
- Floor Construction: 3 Hours (2 Hours with approved automatic sprinkler system 13-60-100(n)) (2 Hours per IBC Table 601)

It should be noted that tested systems for the proposed CLT assemblies do not to our knowledge currently exist. Proposed systems can be developed that through calculation can meet the fire resistive ratings. If this direction is pursued additional testing is required to confirm that the proposed systems do in fact meet the fire resistive requirements. While this is potentially feasible, it is not possible to classify the structure as non-combustible, a prescriptive requirement of Type IA construction. Therefore the structure itself can't fall within the existing framework of the prescriptive code classifications. This requires a performative design approach in which the intent of the code is met.

Performative Design

The International Code Council recognizes that scenarios exist which fall outside the prescriptive requirements of the ICC Codes including IBC. The purpose is identified in Section 101.1 of the ICC Performance Code for Buildings and Facilities [3.3] “to provide appropriate health, safety, welfare, and social and economic value, while promoting innovative, flexible and responsive solutions that optimize the expenditure and consumption of resources.” One of primary purposes of this research is to determine the feasibility of using mass timber for the structural system to minimize the embodied carbon footprint of a building. This is a responsible solution that aims to optimize the use of natural resources and minimize the environmental impacts inherent in tall buildings while still providing the appropriate level of health, safety and welfare. We believe that this falls within the intent of the Performance Code.

Performative design is an approach in which the end result is identified rather than the specific requirements of how to achieve the result. The design professionals are responsible to prove that the design meets the accepted level of health, safety and welfare. The challenge is to prove that a timber structure can be designed to maintain the same or higher level of safety as a building designed to meet the prescriptive requirements identified within the code.

Chapter 17, Fire Impact Management of the ICC Performance Code for Buildings and Facilities identifies the basis of the performative code and includes four main components:

1. Prevent serious injury or death from a fire for all persons directly adjacent to or involved in the ignition of a fire.
2. Limit the magnitude of the property loss.
3. Provide appropriate measures to limit fire and smoke spread and damage to acceptable levels so that fire fighters are not unduly hindered in suppression or rescue operations.
4. Limit the impact of a fire on the structural integrity of the facility.

To prove these requirements are met, a detailed engineering analysis is required to be developed and analyzed to determine the design fire intent, range of fire sizes and potential fire scenarios. More on this subject was discussed in section 2.6 Considerations for Structural Design for Fire.

3.3 Core Design and Modifications from Benchmark: Ref. Sketch A-03, A-04, A-05

The design for the Dewitt-Chestnut building was completed in 1963 and was designed to meet the requirements of the time. The centralized core was compact and efficiently designed to maximize the floor rentable area. A single corridor through the core allowed access symmetrically to the units on each side of the tower with additional entry to the north and south from the center of the core. Two stairs were provided at each end and two banks of two passenger elevators served the low and high rise zones respectively. A single service elevator with vestibule and trash chute was also provided.

The current design of the core has been modified only to allow for the design to reflect current rental market conditions, applicable codes, standards and best practices. The central corridor has been widened to six feet and the stairs expanded to include an Area of Refuge per Chicago Building Code Requirements. The previous arrangement of four passenger elevators has been replaced with three passenger elevators serving all apartment floors. A single service elevator remains and has been sized to meet current requirements. Electrical, Telecom and CATV space has been allocated within the core as required in this type of building.

The original building measured 124'-6" by 80'-0". The current design has been modified to an overall dimension of 124'-0" by 84'-0" which is based on a 4'-0" planning module typical of residential high rise design. This is reflected in the structural system including the core, column and shear wall layout.

3.4 Floor to Floor Height and Modifications from Benchmark: Ref. Sketch A-08, A-09

The existing Dewitt-Chestnut building is designed to have a floor to floor height of 8'-9" with an 8" concrete slab and carpet for the finish floor. This allows for an approximate floor to ceiling height of 8'-1" within the living area. At the kitchen and bathrooms, a drop ceiling is installed to allow for building system routing leaving a 7'-1" ceiling height. To match this condition and provide equal ceiling heights within the timber project the floor to floor height must be increased by approximately 3". The base option in this report reflects the increase in floor to floor height.

For rental apartments in the current market, the clear floor to ceiling height in the living area should be 8'-6" but can be as low as 8'-0". To achieve this, the floor to floor height must increase between 3" and 9". Over the course of 42 rental floors, the increase is significant and has a compounding affect where the additional height requires additional structural material, increased façade surface area and can force area reductions where building height is restricted.

For high-end condominiums, the clear floor to ceiling height in the living area should be 9'-6" but can be as low as 9'-0". In this scenario, it is typical to put a drop ceiling in the living space as well to allow for additional flexibility in the building systems and lighting design. Again the overall height increase is significant especially when compounded over 42 condominium floors.

The reasons for this and the specifics to the floor to ceiling heights are discussed in further detail in the Interior Architectural Design portion of the report.

3.5 Discipline Coordination

Building system coordination is handled in much the same way that a conventional steel or concrete building is designed. Primary mechanical and plumbing systems are routed vertically within the units and distributed on a floor by floor bases. Electrical, Telecom and Data is routed through the core and distributed to the units on a floor by floor bases. This is similar to the original building design.

Mechanical

A vertical fan coil system with heat pumps in each unit are used for the apartments. A condensate pipe is required at each floor and must be coordinated within the 1'-0" drop ceiling above the kitchen / bathrooms and below the link beam.

Electrical

Electrical, data & telephone conduits are run vertically through the core and are distributed to each unit within the ceiling. Each must also be coordinated with the link beams.

Plumbing / Fire Protection

Sprinklers and gas pipes are routed vertically within the core to the units passing below the link beam. Every eight floors cold water pipes, hot water pipes and hot water return pipes are required to be routed from the core to the units requiring a penetration through the concrete link beam at the core.

Vertical Transportation

The original design for the Dewitt Chestnut building included four passenger elevators, two serving the low rise and another two serving the high rise. We believe that the current unit count can be accommodated with the use of three passenger elevators serving all floors. The single service elevator remains.

Of significance to the timber design are the divider beams required between passenger elevators. Typically, these are welded to embedded steel at each floor, but can be bolted at each floor as required to limit the potential for damage to the structure.

3.6 Acoustical Performance Requirements and Design Ref. Sketch A-07, A-08, A-09

IBC Section 1207 requires the design of the walls, partitions and floor/ceiling assemblies separating dwelling units from each other or from public or service areas to have a Sound Transmission Class (STC) rating of not less than 50. Floor/ceiling assemblies between dwelling units or between a dwelling unit and a public or service area within the structure are to have an Impact Insulation Class (IIC) rating of not less than 50. The Chicago Building Code has similar requirements. Both of the ratings are considered minimum requirements and are not sufficient for either rental or condominium design. For rental apartments the STC and IIC of the floor/ceiling assembly are to be designed to 55 and for high end condominiums the STC and IIC are to be designed to 60.

In a concrete construction system such as the flat plate used in the original Dewitt-Chestnut project, the acoustical ratings are inherently higher and require less surface treatment to achieve the required ratings. As an example, a 6" concrete flat slab has an approximate STC rating of 55 and IIC rating of 34. Simply adding the carpet finish can increase the IIC and STC to levels exceeding those identified in the code. These ratings can vary based on a number of factors. A slightly thicker 5-Ply CLT panel approximately 6" thick has an approximate STC rating of 39 and IIC rating of 24 according to the US CLT Handbook [3.4]. This requires that additional surface treatment be provided for CLT construction that would not otherwise be required for flat slab concrete construction.

Meeting the required STC and IIC ratings can be achieved in a number of ways through either floor or ceiling treatment or a combination of both. Many different tested and estimated systems currently exist that can be used to meet the acoustical requirements. In the case of high rise design a premium is placed on the depth of the "ceiling sandwich" since an increase in the thickness directly corresponds to an increase in the floor to floor height and compounds to an overall increase in building height. A few options of how to address the acoustical requirements are shown in the Acoustical Separation Diagrams, A-07, A-08 and A-09. The poured gypsum concrete with underlayment mat was chosen as it provides benefits beyond the acoustical performance by acting as a leveling surface and provides separation from the CLT as discussed in the following section.

Horizontal separation must also be considered for the residential units where they are directly adjacent to core elements such as shafts, stairs, elevators shafts, public corridors and other residential units. Walls and partitions are to have a minimum STC of 55 for both rental apartments and condominiums. In these cases, an exposed CLT wall will not provide the necessary STC rating and again requires additional materials. This increases the thickness required for base building elements and must be factored into the interior design.

All of the acoustical requirements can be met with either conventional or new systems. The use of different types of floor or ceiling treatments all have trade-offs that must be factored into the design including aesthetic impacts and differences in floor to floor heights.

3.7 Moisture Protection and Pest Resistance Ref. Sketch A-08

All structural materials require protection from moisture in order to have long term durability. Wood structures are no different and may be damaged with prolonged exposure to moisture. Care must be taken at areas susceptible to moisture such as kitchens and bathrooms. Consideration must also be given to specific events that will cause large amounts of water to be discharged within the building such as sprinklers.

As discussed in Section 2, the structure below level 2 is concrete. Additional durability is gained with a concrete structure at and below ground level. This has the added benefits of minimizing exposure to moisture especially during construction and providing a separation between the CLT panels and the ground surface which could help reduce the potential for pest infestation. Additional study is required to determine the extent and type of preservative treatments that are required to provide additional defense against decay and pest infestation.

Moisture protection can be achieved for the CLT floors at level 2 and above by providing a poured gypsum concrete topping. While this is not a waterproof membrane it will still provide separation from the wood floor structure reducing the potential damage that could occur from leaks that may go undetected for a prolonged period of time. The poured gypsum concrete also acts as a leveling bed to create a flat surface for the finish floor to be installed. At the bathrooms and kitchens, additional waterproofing systems should be used as would be required in other types of construction.

The walls are not currently designed with any means of waterproofing that would protect the CLTs from exposure to water such as that from sprinkler discharge. Additional testing or analysis should be done to determine if this could cause any long term problems.

3.8 Exterior Wall Design Ref. Sketch A-11

The building is designed to show how timber might be used in the structural design of mid to high rise buildings without limiting the type of façade that can be used. The precast perimeter spandrel beam allows the connection of the façade to the base building to be similar to a concrete or composite deck system. In this case, embeds for the façade anchors can be coordinated within the precast prior to shipment to site. This allows for the exterior wall to be constructed without the need to wait for the cast in place portion of the perimeter to be cast. For the timber spandrel beam option noted in the appendix additional study is required to efficiently integrate the anchors while maintaining the fire separation requirements..

The design of the façade itself can vary depending on a number of factors. Materials selected should be based on minimizing the embodied carbon footprint. This can be achieved through a number of methods including the use of recycled materials, locally and regionally sourced materials, etc. Facades with timber elements can be utilized in areas not requiring rated or non-combustible exterior walls. Limiting the window to wall ratio, high performance glazing and shading devices can all contribute to lowering the carbon footprint through the life of the building.

Section 4: Interior Architecture Design

4.1 Interior Architecture Design Overview

A 42 story timber building not only needs to be buildable and sustainable, it must also be usable and sellable. This is to meet the different market trends and demographic needs in various regions throughout the world. The building must be flexible in its layouts so individual residential units can grow and decrease in size to be reflective of the market demands along with future conversions of the existing spaces with minimal disruption and major reconfiguration. The interior architectural design is a key component to how a building functions, how it is maintained and how it lives. Creating a four-foot wide window module, the interior spaces can be demised to meet ideal spatial configurations while maximizing the functional spaces. Minimal columns along the exterior wall and a small center core allows for maximum exterior exposure. The shear walls run parallel to the units and are used as the main demising wall between various unit configurations. All of the layouts have the primary living and sleeping areas with full glass walls to maximize day-lighting and promote health and well being.

4.2 Overall Organization

This study looks specifically at the current market trends of Chicago but can be modified to meet most demands in many urban markets. This study covers two scenarios; rental apartments and high-end condominiums. The major difference between these two markets is the overall size of the units. Most rental apartments are smaller in size with short term tenants who generally have smaller, portable furniture and less items overall. The high-end condominiums are larger with long term owners who generally have larger, less portable furniture and more items overall.

In planning apartment units or high-end condominiums in a high-rise building and to make it economically feasible, the building should be set up to have repetitious interior components, yet incorporate flexibility. For this research project using wood products as the structural base system, the concept of “stacking modules” is introduced. These modules demonstrate how the apartment building can be set up to allow for units to increase or decrease in area and program to respond to changing market conditions. Advantages with using Stacking Unit Modules include:

- Maximum flexibility with program mix
- High efficiency with MEP systems because plumbing risers and mechanical shafts within the units stack vertically with minimum transfers even as units change vertically
- Construction time may decrease because vertical elements stack
- Ability to use pre-fabricated interior assemblies such as kitchens and bathrooms countertops and cabinets

4.3 Organization of Interior Components

In planning the condominium and apartment units within a high-rise and to make it economically feasible, the building should be set up to have repetitious interior components yet incorporate flexibility. For this research project using Wood as the structural base system, the concept of “stacking modules” is introduced to demonstrate how apartment building can be set up to allow for units to increase or decrease in area and program to respond to changing market conditions.

a. Advantages with using Stacking Unit Modules:

- i. Maximum flexibility with program mix
- ii. High efficiency with MEP systems because plumbing risers and mechanical shafts within the units stack vertically with minimum transfers even as units change vertically
- iii. Decrease in construction time because vertical elements within apartments stack
- iv. Ability to use pre-fabricated interior assemblies such as kitchens and bathrooms countertops and cabinets

b. Types of Unit Modules

There are 3 types of Modules used:

“A” Modules are stand-alone One Bedroom Units

“B” Modules are stand-alone Studio Units

“C” Modules are Bedroom Unit that can be added to “A” Modules to increase unit program and area

c. Set up of Unit Modules

“A” Modules are placed on the 4 corners and in the center location on the wide face of the floor plan. “B” Modules are placed in between “A” Modules. This set up provides only

One Bedroom and Studio Units on a floor as these 2 unit types typically are the largest requirement programmatically for a Rental Apartment building. When a Two or Three

Bedroom unit is required; the “B” Module can be switched out and be replaced with “C” modules. By connecting the “C” Modules with the “A” Modules, a larger unit can be provided on a given floor.

d. Exterior Wall Module

All Unit Modules are set up so that all demising and interior partition walls align with the 4 feet Exterior Wall Module.

4.4 Structural System Impact on Interiors

From an interior planning perspective, there were no unique challenges or limitations with the base Wood structural system compared to a conventional concrete structural system.

4.5 Rental Apartments

Best Practice Metrics

The planning for an efficient floor plate for a Rental Apartment high-rise in the downtown Chicago market typically will have the following:

- a. A central core with a central circulation spine to serve as the public corridor
- b. The lease span, or dimension from the face of the core to the inside face of exterior wall, should be in the range from 27'-0" to 29'-0"
- c. To have only perimeter columns and minimize interior columns and shear walls to maximize flexibility in unit planning
- d. The exterior wall module should be 4'-0".
- e. The clear ceiling height in the primary living space (living room & bedrooms) should be ideally 8'-6", or 8'-0" at a minimum.
- f. The clear ceiling height in the secondary spaces (kitchen, bathrooms, and corridors) should be 7'-6", or 7'-0" at a minimum.

Market Unit Sizes Target

For the Chicago Rental market, unit sizes are typically in the following range:

- Studio or Convertible: 450 - 600 sf
- 1 Bedroom: 700 - 850 sf
- 1 Bedroom + Den: 850 – 1050 sf
- 2 Bedrooms: 1100 – 1500 sf
- 3 Bedrooms: 1600 – 1800 sf

A typical program mix may be in the following range:

- Studio or Convertible: 20-25%
- 1 Bedroom/ 1 Bedroom + Den: 30-35%
- 2 Bedrooms: 25-30%
- 3 Bedrooms: 10-15%

4.6 High-End Condominiums

Metrics: Best Practice

The planning of an efficient floor plate for a high-end condominium high-rise for the downtown Chicago market typically will have the following:

- a. A central core or offset core
- b. The lease span, or dimension from the face of the core to the inside face of exterior wall, should be in the range from 33'-0" to 36'-0"
- c. To have only perimeter columns and minimize interior columns and shear walls to maximize flexibility in unit planning
- d. The exterior wall module should be 4'-0"
- e. The clear ceiling height in the primary living space (living room & bedrooms) should be ideally 9'-6", or 9'-0" at a minimum
- f. The clear ceiling height in the secondary spaces (kitchen, bathrooms, and corridors) should be 8'-6", or 8'-0" at a minimum.

Market Unit Sizes Target

For the Chicago high-end condominium market, unit sizes are typically in the following range:

- 1 Bedroom: 900 - 1250 sf
- 2 Bedrooms: 1400 – 1800 sf
- 3 Bedrooms: 1900 – 2500 sf
- 4 Bedrooms: 3200 – 3700 sf

A typical program mix may be in the following range:

- 1 Bedroom: 10-15%
- 2 Bedrooms: 35-40%
- 3 Bedrooms: 40-45%
- 4 Bedrooms: 5-10%

Section 5: Building Services Design

5.1 Mechanical Systems

Heating and cooling needs for the Prototypical Building will be provided by the implementation of water to water independent heat pumps in each residential unit. A constant temperature central condenser water loop will be connected to a roof mounted cooling tower and a high efficiency gas fired boiler to either supply or reject heat to the circulation water loop.

A variable volume exhaust system will be designed and installed to serve each kitchen, toilet and bathroom providing minimum code required ventilation. Treated make up air will be supplied to common corridors and elevator lobbies at each floor creating a positive pressure environment on the common spaces and an air flow stream from the lobby to units to exhausted areas.

It is believed that the extensive use of wood in the building structure will not affect the selection of these mechanical systems.

The expected interior air humidity of the building will fluctuate during different seasons ranging from as low as 20% in the winter to over 70% in the summer. Sustained fluctuations are expected to be in the range of 40% to 60%. In general terms, bathrooms are the only areas expected to have saturated conditions and only after prolonged periods of hot water baths and showers. The dedicated exhaust systems will be designed to minimized these instances and shorten the exposure of materials to these conditions.

Although circumstances will occur in an occupied residential building that may seem to be detrimental to the timber, these conditions are not expected to be sustained periods long enough to be a substantial design concern.

5.2 Plumbing Systems

The domestic water system will be supply by the city's water main with a combined domestic water / fire protection dual metered water service into the building. Water will be provided to the residential units by high and low zone booster pump assemblies. Each pump assembly will supply two vertical water zones. A central domestic hot water system will supply hot water to all plumbing fixtures. The main pump equipment room and residential unit bathrooms are required to comply with section 18-29-405.2.1 of the Chicago Building Code which requires a non-absorbing floor material. Refer to section 3.7 for additional information.

5.3 Fire Protection Systems

Fire protection water supply will be provided with double detector check valves from the combined domestic and fire protection water service. The building will be provided with a combined fire standpipe and automatic sprinkler system. The building will be divided into two zones, a high and a low level, each with one set of fire pumps. The low and high level fire pumps will be connected in series.

With wood construction all combustible concealed spaces greater than 6" will be required to have sprinklers per NFPA 13, 2013, section 8.15.1, or be completely filled with non-combustible insulation. Combustible concealed spaces include ceiling cavities, wall cavities, floor cavities, plumbing / electrical / duct shafts and chases. Pipe chases that are under 10 square feet and are fire stopped at each floor with a fire rating equivalent to the floor are not required to be sprinklered. Requirements using a performance based design approach may vary and need to be determined with input from code officials.

5.4 Electrical Systems

The electrical system will be designed with a medium voltage distribution approach. Medium voltage is recommended to reduce the requirement for large bus duct riser shafts within the core. Substations will feed typical floors via bus ducts from a lower level as well as from a penthouse level, halving the required number of bus ducts through a particular floor. Considerations have been made regarding equipment weight at upper levels, heavy equipment removal pathways to elevators, as well as required fire rating of shafts.

Section 6: Embodied Carbon of Structure

6.1 Overview

The material in this section is intended to serve as a preliminary investigation into the environmental impact of using wood (notably mass timber and glued elements) as the primary structural material for a tall building. The reinforced concrete structure of the Benchmark Building is compared to the composite-timber structure proposed for the Prototypical Building. This section does not include a full life-cycle assessment (LCA); instead, the focus is the embodied carbon of the materials used (concrete, steel, and timber quantities) as well as the carbon emissions associated with the energy used to construct the building.

One of the reasons for restricting the discussion primarily to a material-based rubric (i.e., “cradle-to-gate” embodied carbon for the structural system) is to provide a point of comparison between wood, concrete and steel buildings that is not necessarily provided by or accounted for in existing rubrics like cost per square foot (\$/sf), weight of material per square foot (lb/sf) etc. Another factor is the evolving consensus on the limits of a LCA [6.6, 6.14-6.18] and difficulty in obtaining accurate data for CLT, Glulam, and heavy timber systems [6.1-6.4]. The preponderance of existing data is for “traditional” structural systems and materials, i.e., structural steel, reinforced concrete or dimensional lumber [6.5].

There are several recent LCA studies that compare different structural systems and building types [6.11-6.14], but these do not focus on mass timber. Research has been done on the carbon impact of wood in residential construction [6.3] and more recently LCA for mass timber CLT buildings has become available such as the information provided in the US CLT Handbook [6.23].

Finally, it should be noted that this section includes the effects of carbon sequestration on the embodied carbon footprint of the wood building. There are currently differing positions on the extent that sequestration should be considered on the carbon footprint of any material [6.15, 6.16-6.18, 6.19]; however, the magnitude of wood’s ability to sequester carbon (compared to concrete for example [6.15, 6.22]) is deemed as significant and worthy of inclusion.

6.2 Materials Used

The materials discussed below are discussed further in Section 2.3.

Wood Products (Walls, Floors, Columns and Interior Beams)

Laminated wood is a composite (wood/adhesive) material which exhibits higher strength and stability than traditional wood. Common types of laminated wood include: laminated veneer lumber (LVL), parallel strand lumber (PSL), cross laminated timber (CLT), and structural glued laminated timber (Glulam). Each of these products can be built up using softwoods.

The cost of softwood is relatively low; significant costs associated with CLT and Glulam product are related to the the process of building up the timber members and the adhesives used in the process. Wood is plentiful throughout Canada (notably British Columbia), the Pacific Northwest, South and Midwest (Minnesota and Wisconsin) and the use of local wood reduces the cost of transportation and also earns LEED credits for the use of local materials. Moreover, existing manufacturing technology required for these products is well established which permits construction without extensive re-tooling.

Additional considerations were made in the development of the proposed system to further improve the sustainability of wood products including the use of heavy timber and air drying of wood. These considerations are outside the typical manufacturing processes used today for mass timber products but could be embraced by the industry in the future to increase the sustainable advantage of wood products. The use of heavy timber in structurally glued elements has the ability to reduce the adhesives required by as much as 70%. Examples of these elements are shown in details 1-3 on sketch S-05. Another consideration to improve the sustainability was air drying of wood members. According to values extrapolated from Puettmann and Wilson [2005] air-drying (AD) of members can contribute has up to a 70% carbon savings compared to kiln-drying (KD). In addition to carbon savings, air-drying results in stronger and more stable timbers due to the gradual drying – especially for timbers of large cross-sectional area.

Concrete (Joints, Link & Spandrel Beams, Lower Levels, Foundations, Topping Slabs)

Normal strength concrete is used throughout the building. The sustainability of the concrete is improved by using cement replacement (i.e., fly ash and ground granulated blast-furnace slag). The results below show the effect of a 60% replacement (40% cement, 60% other) [8-10].

Steel Reinforcing and Structural Steel

No special considerations were made for these materials.

Material Quantities

The structural material quantities for the Benchmark and Prototypical Building are reported in Section 2.2. These take-off and estimated quantities are used as the basis for the calculated embodied carbon footprints of the Benchmark and Prototypical Building structures. The substructure and foundations were included in the analysis. The architectural topping slabs required for the proposed composite-timber system were not included in the structural quantities reported in Section 2.2. The topping slabs were included in the embodied carbon calculation for the Prototypical Building reported below.

6.3 Calculation Assumptions

Two scenarios are considered. The first is a ‘standard materials’ comparison which does not consider sustainable options such as cement replacement and air drying of wood. The second scenario is referenced ‘sustainable material options’ and considers cement replacement and air drying of wood. Both scenarios are taken as “cradle-to-gate” for the embodied carbon footprint of the materials used.

The carbon emissions associated with construction were estimated to be 16 lb CO₂e/sf based on [6.24-6.26]. This value was used for both the Benchmark Building and Prototypical Building. It is unlikely that the compared structural systems would have equal carbon emissions associated with construction. However, they were taken as equal for this study in the absence of data related to the construction of composite concrete-timber structures.

Assumptions: Standard Materials

1. CO₂ equivalent values for concrete, steel and timber (i.e., sawn softwood) are obtained from Hammond et al [6.5].
2. CO₂ equivalent values for Glulam and CLT are based on [6.2-6.5].
3. CO₂ equivalent values for wood products include carbon sequestration.
4. CO₂ equivalent values for the steel assume standard recycled content.
5. Wood is kiln dried.

Assumptions: Sustainable Material Options

1. CO₂ equivalent values for concrete with cement replacement (fly-ash and ground granulated blast-furnace slag) are taken from [6.8-6.10]. Replacement assumes 60% of the cement is replaced with fly ash (20%) and GGBS (40%).
2. All wood is assumed to be air-dried. The impact of air-drying as presented results in a 70% reduction in the CO₂ equivalent values for wood.

6.4 Analysis Results

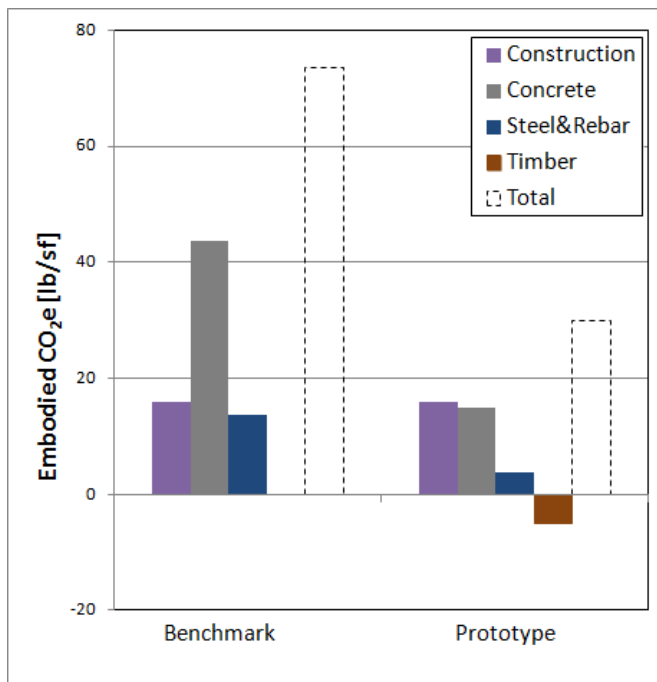

Figure 6.1: Embodied Carbon Footprint Comparison, Standard Materials

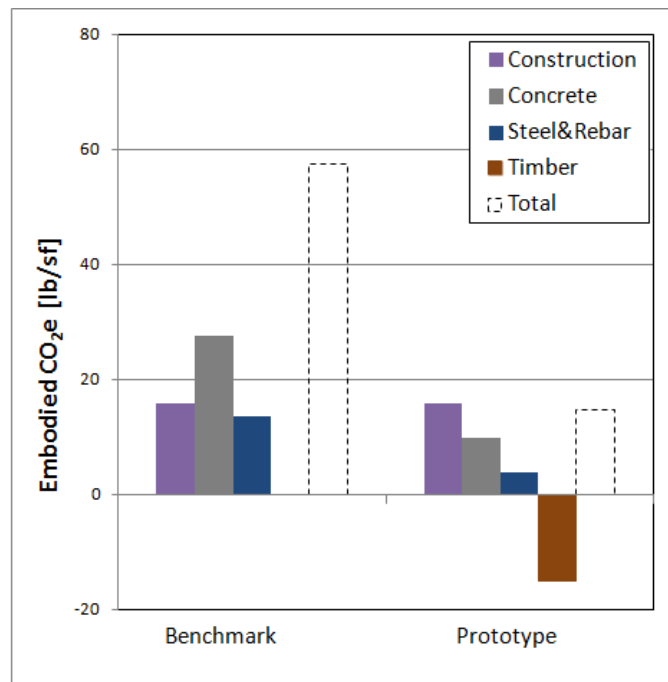

Figure 6.2: Embodied Carbon Footprint Comparison, Sustainable Material Options

6.5 Conclusions

The embodied carbon footprint Prototypical Building structure has been estimated to be 60 to 75% lower than that of the Benchmark Building structure. These results are clear; the composite timber structural system documented has a significantly lower embodied carbon footprint compared to a conventional reinforced concrete system. The use of more sustainable concrete reduces the carbon footprint for both buildings with the Prototype Building still well below the Benchmark Building.

Section 7: Recommendations

7.1 General

The proposed structural systems were developed using engineering first principles approach and are expected to perform as intended. These expectations must be verified with additional research and physical testing before they can be implemented in actual buildings. This section of the report outlines recommended additional work. Possible research is addressed first followed by recommended physical testing.

7.2 Research

Specific recommendations for additional research are reported below.

Structural

The following structural studies should be considered:

1. Additional detailed analytical modeling of connection behavior to complement a physical testing program. Suggest non-linear modeling of timber-concrete connections to capture losses in stiffness due to localized failures of timber in bearing and reinforcement slip. This modeling should be done for the timber floor to concrete connections, timber walls to concrete link beams, and timber columns to concrete spandrels.
2. Structural interaction between timber and concrete related to creep and shrinkage. The concrete joints shrink due to curing and will creep under load. The timber members will also creep in addition to shrinking and swelling due to moisture changes. These self-straining forces may affect the connection details. Design criteria need to be developed and the system analyzed to determine if any additional requirements are necessary.
3. Seismic performance. Tall building designs in Chicago are typically not controlled by seismic forces. If the system will be used in more active seismic regions, additional research on seismic performance is recommended. Considering this, the seismic design criteria for the system will need to be determined. At minimum, two items need to be studied ahead of the required physical testing discussed in Section 7.3: connection ductility and global behavior. First, detailed modeling of connections in the lateral load resisting system could be studied to determine detailing requirements to improve ductility on an element basis. Second, geometric and material non-linear time history analysis could be performed to approximate system response modification factors. This analysis could also help with the development of system seismic modification factors for future building codes.
4. Disproportionate collapse. The reinforced concrete elements in the system can be designed for extreme event robustness with catenary behavior that might be required following the loss of a column. The reinforcing details necessary to provide the required robustness need to be determined by analysis and testing.
5. Research possible uses of wood elements in concrete and steel buildings. For example, can CLT replace composite metal deck slabs in steel framed buildings?

Architectural

The following architectural studies should be considered:

1. Durability detailing. Additional studies should be done to determine the necessary details at all concrete/timber joints for long-term durability. Studies should include cost-benefit analysis of cost and total design life.
2. Impacts due to moisture or water exposure should be studied for areas that may be exposed for long periods of time or to a large amount of water.
3. Additional study to determine the pest resistance through preservative treatment.

Fire Performance

A fire engineer should review the proposed structural systems and connections and help develop necessary performance based design criteria and details. It is recommended that the fire engineer address the following:

1. Establish performance-based fire design criteria specific for tall wooden buildings.
2. Develop fire design criteria specific to composite timber-concrete systems.
3. Determine necessary physical fire tests.
4. Create fire models to establish required exposure times.
5. Perform detailed thermo-mechanical analyses of the timber to concrete and exterior wall to structure connections including the behavior of the epoxy resins.

Fire engineering research work should be performed in parallel with physical testing.

Construction

A construction engineer or contractor should review and comment on the systems and possible erection sequence. It is recommended that the construction engineer address the following in their review:

1. Determine the trade unions to be involved and identify potential work flow issues.
2. Determine probable construction schedules including lead-time requirements for mass timber materials.
3. Review and comment on possible erection methods and sequencing.
4. Develop methods for vertical adjustment to compensate for shortening of column and walls.

Manufacturing

Mass timber industry representatives should review and comment on the products/materials and systems so that the design can be optimized. The following should be considered by the manufacturer:

1. Determine the manufacturing and installation processes and limitations of reinforcement epoxy connected to timber.
2. Heavy timber members. The manufacturing limitations and costs associated with using wood members thicker than 2" and even heavy timber to build up the alternates shown needs to be understood.

Cost Estimating

A cost estimator should review the proposed systems in conjunction with construction engineering and manufacturer comments in order to estimate the total cost of the system. Specific attention should be given to new details and new uses of products and materials. Comparisons of alternate materials, manufacturing processes, and erection sequences and schedules should be included.

Code Consultant

A code consultant should evaluate the results of this report and develop appropriate performance based design requirements for high-rise mass timber buildings. These design requirements should consider the level of service currently provided by the prescriptive design of reinforced concrete and structural steel buildings.

7.3 Physical Testing

The following physical tests are recommended. Detailed testing programs will be developed in conjunction with research work. Additional tests will likely be required based on initial results.

Structural

The following physical tests are recommended:

1. Testing of the timber floor connection to concrete joint. Test to determine the moment-rotation behavior of the joint for both small loads (walking excitations) and large loads (ultimate strength design). Multiple connection configurations should be tested to optimize the design for load distribution between horizontal and vertical force couples.
2. Testing of the concrete beam to timber column joint. Test to determine the moment-rotation behavior of the joint for both primary bending and torsion. Test may include column axial compression.
3. Testing of the concrete wall joint for floor restraint. Test to determine the moment-rotation behavior of the floor joint. Test may include wall axial compression.
4. System vibration test. Test the entire assembly of floor and vertical elements for vibration characteristics.
5. Testing of the timber wall with concrete joints. Test the shear and bending moment transfer through the concrete joints that would occur at each floor. Determine vertical steel required for load transfer.
6. Testing of the concrete link beam to timber wall connection. Test the assembly to determine total system stiffness and establish sources of stiffness losses compared to theory. Determine overall system ductility and behavior. Determine boundary element detailing requirements.

Architectural

The following physical tests should be considered:

1. Durability testing. Test cyclic humidity and moisture on representative components of the structure to study the durability of the system at timber/concrete interfaces
2. Acoustical testing to confirm the estimated performance results are achieved.

Fire Performance

A fire engineer should determine the necessary fire performance testing. It is expected that, at a minimum, the following tests will be required:

1. Flammability tests of all exposed timber elements to verify that fires will self-extinguish.
2. Component fire tests. Tests of columns, walls, and floors where elements differ from existing tests.
3. Assembly fire tests. Test of the entire system including the behavior of the concrete joints connecting the timber members including the behavior of the epoxy resins.
4. Scale fire test of one large compartment (30'x 40').
5. Full scale fire test of typical floor panels with end connections.
6. Full scale fire test of typical exterior wall connection to structure.

Construction

A construction mock-up is recommended to demonstrate feasibility. The mock-up may also be considered as part of other tests noted above.

Section 8: Conclusions

8.1 General

This section summarizes the major findings of this report, compares the benchmark Dewitt-Chestnut Building with the Prototypical Building, and presents simple, overall conclusions. The conclusions are based on the design of a Prototypical Building for a specific site and set of program requirements. These conclusions may not apply to all geographic locations, site conditions, and program requirements.

8.2 Major Findings

Structural

1. Mass timber is believed to be a capable structural material for use in high-rise structures. This is because the material can span the required lease depths and has acceptable strength and stiffness characteristics to resist multi-story gravity and lateral loads.
2. Composite structural systems should be strongly considered as using timber, steel, and concrete where they have natural advantages leads to more economical structures and increases the likelihood of building owners adopting the system.
3. Timber is not the ideal material for resisting large loads at critically stressed members such as link beams. These members are best designed in either reinforced concrete or structural steel. These critically stressed members are a major hurdle for 'all-timber' schemes for buildings taller than approximately 15 stories.
4. The lightweight nature of wood makes net uplift a primary concern when designing tall buildings with mass timber. Net uplift can be reduced with efficient structural systems that rely on fewer vertical load bearing elements placed at carefully selected locations. These systems rely on floors which can span long distances and elements which can be designed for higher stresses such as the link beams. The proposed system achieves these goals by using reinforced concrete joints and link beams. The concrete joints also have the secondary benefit of adding dead load to help offset uplift due to wind.
5. High-rise mass timber buildings will generally use less foundation material than concrete buildings. However, there is a higher likelihood that timber buildings will require uplift restraint by the foundations which can generally be avoided in concrete buildings.
6. Differential vertical shortening between the columns and walls due to elastic strain and creep is a significant design and construction issue for timber buildings taller than approximately 20 stories. Design and construction methods to compensate for these movements will be required.

Architectural

1. Mass timber structures generally need acoustic treatments at the floors and walls to satisfy code and best-practice acoustic separation limits. This design issue also exists for low-rise structures and solutions are available. Acoustic build ups on the floors require the floor-to-floor heights to be slightly taller for timber buildings compared to concrete buildings to achieve the same floor to ceiling height.
2. Mass timber structures require care in detailing around potential moisture sources from bathrooms, kitchens, and exterior walls. Supplementary protection systems may be used at these locations to improve the long term durability of the structure. This issue also exists for low-rise structures and solutions are available.
3. The interfaces between timber and concrete need to be detailed in order to achieve appropriate long term durability of the structure.
4. The coordination between the different design disciplines was minimally impacted by the timber structure relative to concrete structures.

Interior Architecture

1. The interior layouts were minimally impacted by the nature of the timber structure.

Building Services

1. The design of building services were minimally impacted by the nature of the timber structure.

Fire Performance

The overseas acceptance of tall timber buildings suggests that tall timber buildings are technically feasible from a fire safety standpoint. Mass timber generally performs well in fires because of charring. The most likely path to realize a tall timber building in the United States is through the use of performance based fire design focused on the specific Prototypical Building design such as presented herein. Working with a forward thinking code authority where special opportunities for innovation exist will also accelerate the process. Lastly, physical testing along with further research and analysis are required to establish and verify the performance based design.

Construction

The construction industry which exists today related to the manufacturing of products, fabrication of structural elements, and construction of tall buildings has developed and evolved over many years. Portions of that industry are already well suited to construction of a tall timber building. Other segments of the industry will need to evolve further to accommodate and refine elements of construction specific to building tall with timber. In particular, the erection sequence proposed and logistics and costs associated with that sequence will naturally improve with experience to result in the most economic result possible for construction of tall timber buildings.

Manufacturing

The mass timber elements proposed are believed to be technically feasible. Manufacturers and designers must work together to develop products which best suit the needs of high-rise buildings.

8.3 Benchmark Comparisons

The following matrix is a comparison of the Prototypical Building and the Benchmark Dewitt-Chestnut reinforced concrete building:

Item No.	Subject	Comparison
S-1	Material Quantities	Benchmark and prototype use comparable structural quantities
S-2	Foundations	Prototype uses less foundation materials than benchmark. Prototype requires uplift restraint, benchmark does not.
S-3	Unit Layout Coordination	Benchmark has columns in the units, Prototype has 4 shear walls on demising walls. Buildings are comparable.
S-4	Embodied Carbon Footprint	Prototype reduces the embodied carbon footprint of the structure by 60-75% compared to the benchmark.
A-1	Acoustic Floor Treatment	Prototype requires a floor build-up to satisfy STC and IIC acoustics. Benchmark required only carpet to satisfy IIC.
A-2	Floor-to-Floor Height	The structure is 1/2" thicker and acoustic & ceiling buildup is 2 1/2". Prototype requires 3" extra floor-to-floor height for equal floor to ceiling height.
A-3	Moisture protection	Prototype requires moisture protection not needed in benchmark.
A-4	Fire Protection	Prototype may require supplementary fire protection based on fire engineer's requirements. Benchmark structure satisfies prescriptive fire requirements with structure only.
I-1	Interior Layouts	The interior layouts are comparable
M-1	Building Services	The building services are comparable

8.4 Summary of Conclusions

The research presented suggests that mass timber is a viable structural alternative to reinforced concrete and structural steel for use in high-rise buildings. This conclusion is based on the following:

1. The structure can be designed to satisfy the intent of the code.
2. The design of the structure does not have significant impacts to the architectural, interior, or building service designs.
3. The structural materials required for a high-rise timber structure appear to be comparable to a reinforced concrete structure suggesting that high-rise timber buildings could be competitive once effective construction methodologies have been established.
4. The embodied carbon footprint of a high-rise timber structure could be approximately 60-75% less than that of a reinforced concrete structure.

There are surely barriers to realization of a tall timber tower and much work to be done. These include a lack of precedents in the United States, additional required testing, and updating appropriate code provisions, particularly related to fire engineering and construction technologies. But results of research summarized in this report suggest that a tall timber tower is technically feasible and efficient on an architectural, structural, mechanical, and interiors design basis. That there are similar projects being built in other areas of the world using the latest in performance based fire engineering, that sustainability is continuing grow overall importance, and that construction technologies will quickly be developed to optimize efficiencies in manufacturing, fabrication, and erection using timber all give reason for optimism and the expectation that tall timber buildings will be a viable choice for owners and will be developed in the United States in the foreseeable future.

Appendix A: Fundamental Engineering Principles

A.1 General

This appendix provides detailed engineering information related to the proposed structural systems. The information presented is related to either a comparison of material properties between steel, concrete, and timber or a tall building engineering fundamental independent of structural materials.

A.2 Material Comparison: Axial Compression Strength

Vertical elements such as columns and walls must support large vertical loads in tall buildings. This section shows that timber is capable of resisting the necessary column and wall compression loads. The large loads are due to the weight of multiple stories above as well as compression from lateral loads. Supporting these loads is the primary reason that tall buildings require more structural material than low-rise buildings. The material quantities needed to support the loads are shown for each material in the study below.

Each of the concrete, steel, and timber columns have each been designed to support 1,200kips of axial compression as would be typical in a tall building. It can be seen from Figure A.1 that timber is capable of resisting the necessary loads with a reasonable column size.

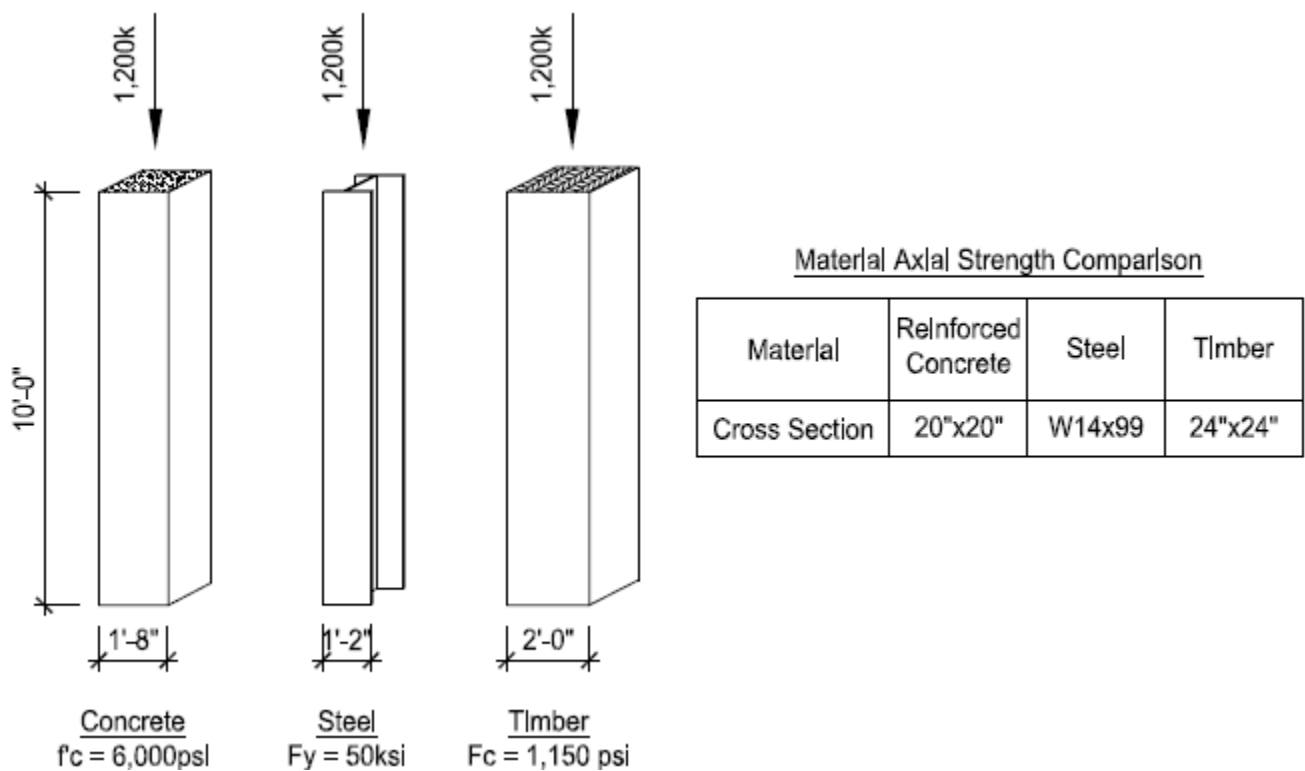

Figure A.1: Material Axial Compression Strength

A.3 Material Comparison: Axial Stiffness

The lateral movement of tall buildings is generally governed by the axial stiffness of lateral load resisting elements. Lateral loads create overturning moments which are resisted by axial forces and stresses in the vertical elements of a tall building. The figure below shows the column movement for the 1,200kip elastic load studied in Section A.2. It can be seen from Figure A.2 that the timber and steel have similar movements for a column sized for strength. It can also be seen that concrete is more than twice as stiff as both the steel and timber members.

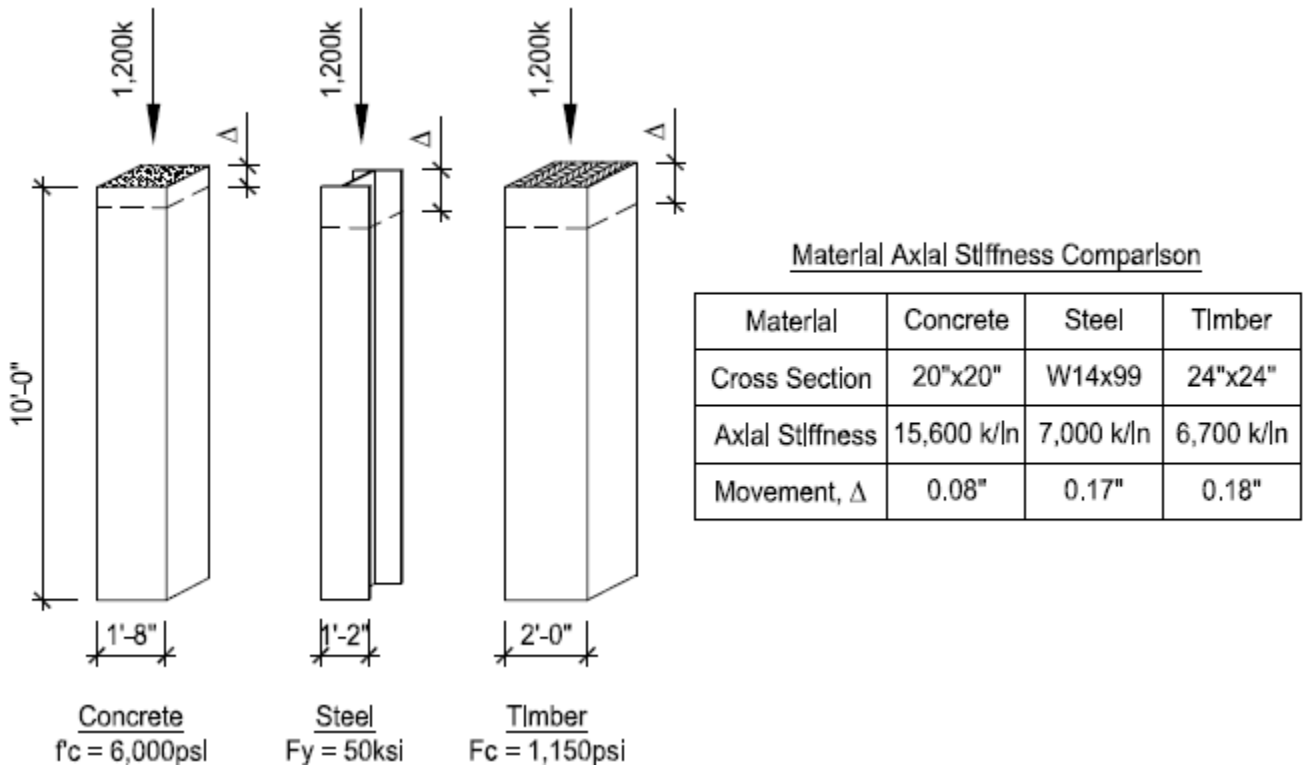

Figure A.2: Material Axial Stiffness

The material elastic stiffness for concrete is approximately 3 times that of timber. A lateral system consisting of timber will therefore either need more material relative to a concrete lateral system or the structural members of the timber system will need to be arranged more efficiently. Extending the North/South shear walls to the exterior walls, the Prototypical Building has been designed with a more efficient arrangement of structural members than would typically be required for a concrete building. It should also be noted that the concrete joints in the proposed system add to the axial stiffness of the wall elements. The concrete joints increase the axial stiffness of the walls by 10-15% depending on the size of the joints relative to the floor-to-floor heights.

A.4 Material Comparison: Maximum Strength/Link Beams

The difficulty in designing link beams is noted in the main body of the report and is the result of practical size limitations of the elements imposed by the architecture. For example, consider the design of a timber column and the design of a timber link beam. The column size can increase from top to bottom of the building as the load increases. The column will intrude further inside the units which is not desirable but easily managed. However, a link beam cannot become deeper in order to resist the larger coupling forces toward the base of the building as making the link beams deeper would require an increase in floor-to-floor height which would be costly and also increase the wind loads. Designing the members to fit within the depths allocated often leads to members that are highly stressed and difficult to design as shown in the example below.

The link beams below have been designed to fit in a 12" wide by 18" deep space. The beams are 4ft long. The maximum shear that a concrete, steel, and timber beam can resist is shown for comparison.

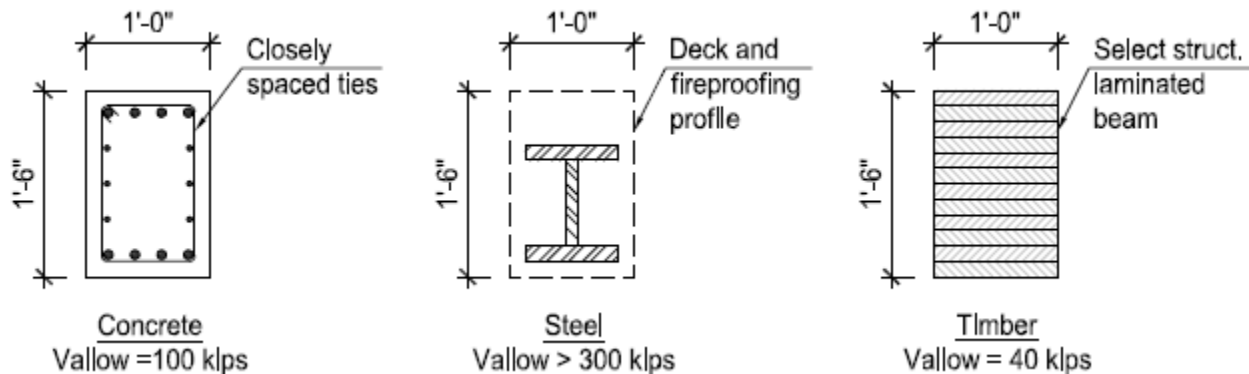

Figure A.3: Maximum Available Link Beam Shear

It is clear that the timber beam has the lowest shear capacity. The link beams in the Prototypical Building must typically be able to resist coupling shear loads in the range of 50-100kips. The link beams would not be able to be designed within the allotted space as a timber beam. This is one of the primary reasons the concrete joints and link beams are used. See Appendix C for additional information on the design of timber link beams.

A.5 Material Comparison: Span End Conditions

The material quantities required in the floor framing system are a significant portion of the total material in a building. This is true even for a tall building. The materials required to span are often related to the end support conditions as these conditions affect the overall stiffness of the floor. The effect of end conditions is shown below.

Two theoretical floor systems are compared, a concrete one way slab and a series of composite steel beams. Each system spans 27'-3", the span length of the Prototypical Building. Two ideal support conditions are compared: simple supports and fixed supports.

If a concrete system is built with fixed end conditions, the concrete system gains a significant advantage because it is controlled by long-term deflections and the fixed end condition system is 5 times stiffer for uniformly distributed gravity loads. The floor can therefore be 60% as thick as the simple supported floor and result in the same deflections.

The steel system cannot take advantage of the fixed supports because it is governed by strength. The fixed end condition in the steel system reduces the maximum moment from $wL^2/8$ at the mid-span to $wL^2/12$ at the supports. This reduction in moment demand is offset by the loss of the composite properties at the support because the slab is in tension. As a result, the steel beam size cannot be decreased, making the fixed-end connections ineffective and more costly for this situation.

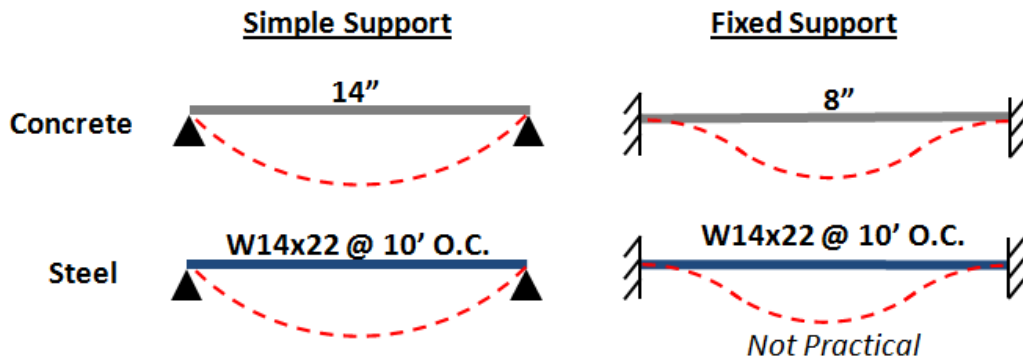

Figure A.4: Floor Systems and Beam Deflection Diagrams

The proposed structural system used in the Prototypical Building is governed by vibrations and deflections similar to the concrete one way slab system. The timber floor system can see similar behavior advantages as a concrete system by providing fixed end connections to the vertical structure. The concrete jointed timber frame system utilizes the reinforcing through the concrete joints to provide this connection. The result is thinner, more economical floor panels that reduce the material quantities in the building.

A.6 Tall Building Principle: Floor-to-Floor Height

Floor to floor height is important in the design of all buildings but it is of particular importance in tall buildings. First, the additional height requires more vertical structure, more cladding area, and more shaft and elevator length. Second, additional height adds wind loads to the building which increases the overturning moment without adding significant mass. This makes net uplift due to wind load more likely. Both of these add to construction costs.

The effect of floor-to-floor height is highlighted in Figure A.5. The graph shows two building heights related to the study shown in the previous Appendix Section A.5. The bar on the left is the total building height if the 8" thick floor system with fixed end connections is used. The bar on the right is the total building height if a 14" thick simply supported system is used (additional 6" per floor). Both bars match the Prototypical Building width and height proportions.

The increase in floor thickness from 8" (fixed ends) to 14" (simple span) adds 21ft to the height of the building. The architectural impacts of this additional height include adding an extra 8,400 square feet of cladding.

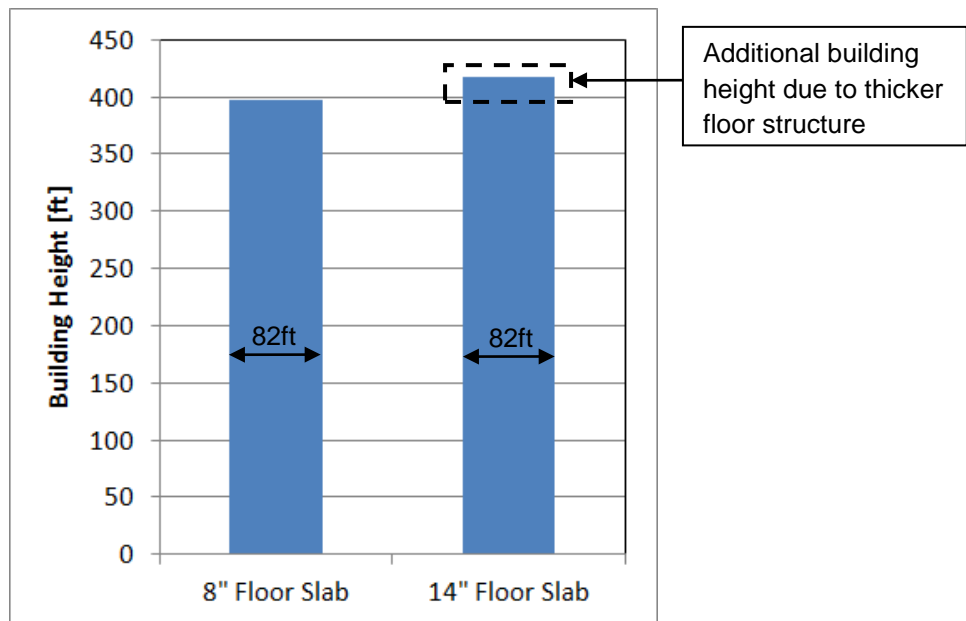

Figure A.5: Total Building Height v. Floor System Chosen

The proposed system for the Prototypical Building attempts to minimize the floor panel thicknesses not only for overall material economy but also to minimize the building height. Minimizing the building height is also important for a timber structure because of its lightweight nature and tendency to experience net uplift due to wind. For example, the fixed end floor connections of the proposed system prevent an additional 5% of building height which would cause a 10% increase in overturning moments. This increase in overturning moment would cause a 20% increase in net uplift due to wind.

A.7 Tall Building Principle: Management of Gravity Load Paths

The management of gravity load paths is an important topic in tall buildings for two reasons. First, maximizing the amount of gravity load which is supported on the lateral load resisting system minimizes the potential for net uplift. Second, gravity and lateral loads need not be considered at their maximum values simultaneously. Lateral load resisting systems which support large gravity loads benefit from these statistical combinations of loads.

The figure below shows the gravity load tributary areas to the lateral load resisting system for the prototypical building. The percentage of the total building gravity load supported by the lateral load resisting system is approximately 65%. This percentage is reasonably high but could be increased to completely eliminate the net uplift experienced by the Prototypical Building. This could be done by using outriggers and belt walls or by engaging the perimeter columns in the lateral load resisting system with a more robust moment frame or braced frame. These solutions were not included in the research in order to keep the system simple and more flexible.

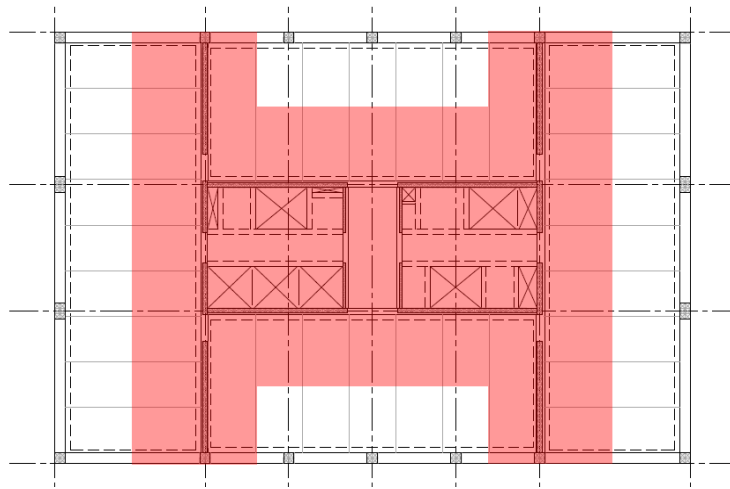

Figure A.6: Tributary Gravity Loads to Lateral Load Resisting System

The axial compression strength checks of the timber walls were typically controlled by gravity load combinations and not wind load combinations. This can be attributed to load combination statistics and time effect factors. Consider the controlling gravity and wind load combinations:

High Gravity Combination: $1.2D+1.6L$

High Wind Combination: $1.2D+0.5L+1.6W$

These two combinations will be equal when $W = 0.7L$. Therefore, the wind load effect needs to be greater than 70% of the live load effect before wind loads control. Managing the gravity loads to maximize live loads on the lateral load resisting system will result in minimum premiums due to wind loads.

The time effect factor from the NDS [A.1] design code also affects the controlling load combination. The gravity load combination receives a 0.8 factor whereas the wind load combination receives a 1.0 factor. The timber shear walls are 25% 'stronger' during the wind event. This along with the gravity load combinations results in few vertical elements being governed by lateral loads and reduces the material premium for height.

A.8 Tall Building Principle: Lateral System Efficiency

An efficient lateral load resisting system will have a large radius of gyration or ‘effective width’. A lateral load resisting system with a larger radius of gyration will be more efficient at resisting wind loads as well as avoiding net uplift. Because the Prototypical Building experiences net uplift, a lateral load resisting system with a large radius of gyration is necessary to minimize the uplift. The proposed system achieves a large radius of gyration by:

1. The North-South walls extend to the perimeter of the building
2. The primary North-South walls are thickened and secondary North-South wall near the center of the building (within the core) are thinned.

These effects are highlighted in Figure A.7.

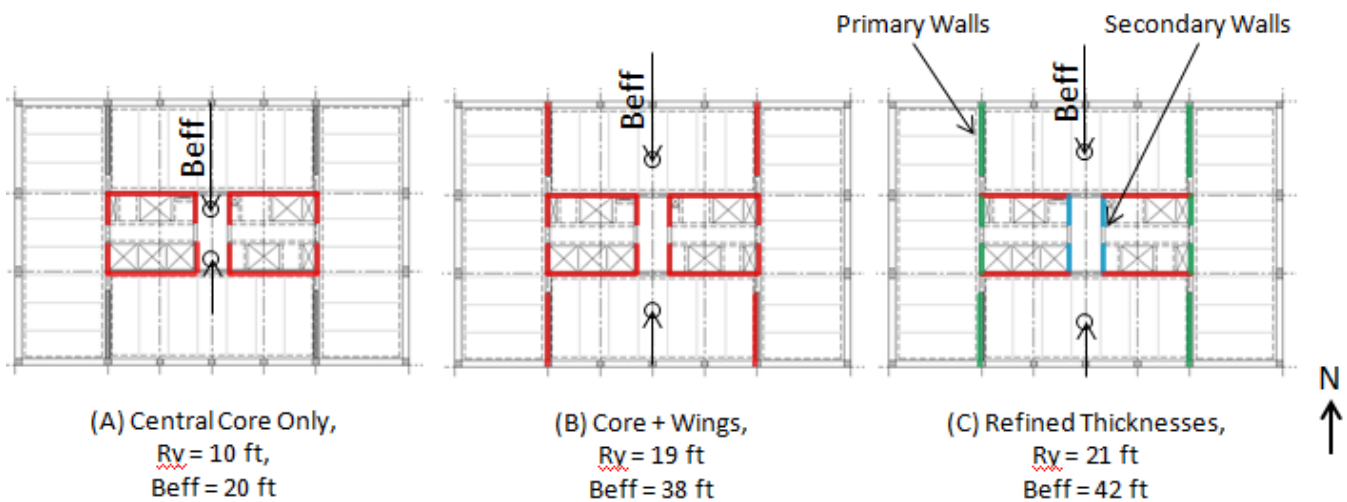

Figure A.7: Lateral System Effective Widths

Figure A.7 shows that the efficiency of the system is improved by 90% by engaging the full depth of the building. The system is further improved by another 10% by thickening the primary North-South walls by 20% and thinning the secondary North-South walls by 40%. Net uplift is the difference between the gravity and wind stresses. Small changes in either load effect can cause large changes in net uplift, highlighting the value of relatively small refinements to the lateral load resisting system.

Appendix B: Interpolation of Results for Shorter Buildings

B.1 General

The height of a building will have an impact on the following issues:

1. Wind load drift
2. Building dynamics (natural frequency)
3. Net uplift due to wind
4. Differential column and core shortening
5. Member sizes (material quantities)
6. Foundations

These issues were studied for 10, 15, 20, and 30 stories relative to the 42 story Prototypical Building documented. Elevations of the building heights studied are shown for reference in Figure B.1. The following changes were made to the Prototype Building:

1. Typical levels were removed for the shorter buildings.
2. The lower halves of each of the buildings have full building depth North-South shear walls and upper halves have reduced North-South shear walls.
3. Shear wall thicknesses are reduced for shorter buildings where practical.
4. The 10, 15, and 20 story buildings are analyzed with and without the coupling link beams. The models which do not use link beams are noted 'no link beam' (NoLB).
5. The concrete structure below L02 was not changed.
6. Roof mechanical level and screen wall are not changed. It is unlikely that these areas would be required for the buildings shorter than 20 stories. However, they are kept in the analysis for consistency and simplicity.

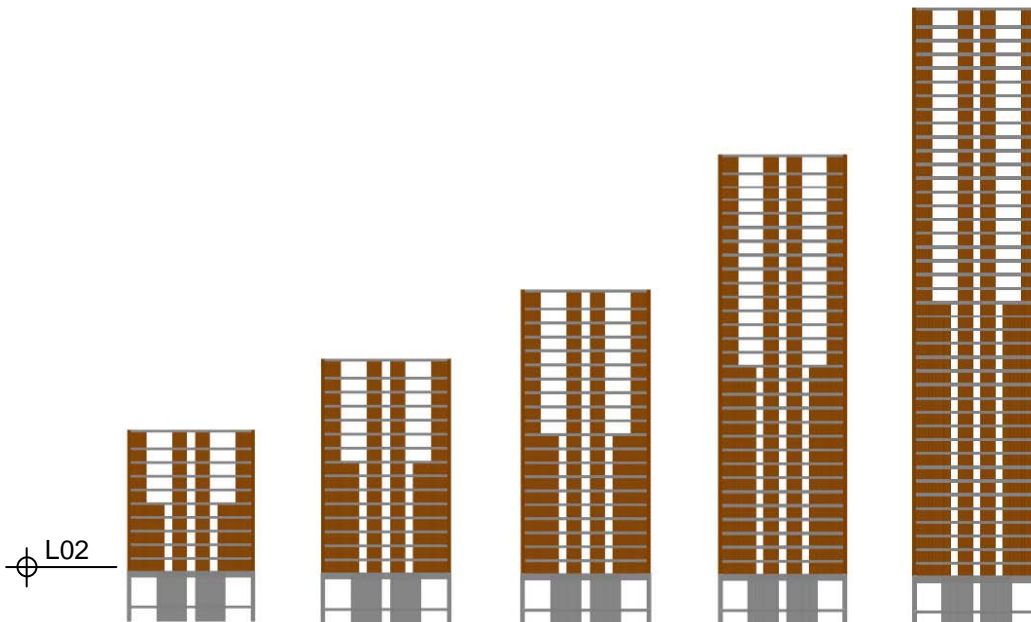

Figure B.1: Building Heights Studied: 10, 15, 20, 30, and 42 Stories

B.2 Comparisons

Wind Load Drift N/S Direction

Wind drift reported is taken as the roof displacement relative to L02.

- 42 Story: H/600
- 30 Story: H/1,000
- 20 Story: H/2,000; 20 Story (NoLB): H/600
- 15 Story: H/3,300; 15 Story (NoLB): H/1,100
- 10 Story: H/5,800; 10 Story (NoLB): H/2,600

Building Dynamics

The fundamental periods of the buildings are as follows:

- 42 Story: 3.6 sec
- 30 Story: 2.2 sec
- 20 Story: 1.4 sec; 20 Story (NoLB): 2.4 sec
- 15 Story: 1.0 sec; 15 Story (NoLB): 1.5 sec
- 10 Story: 0.7 sec; 10 Story (NoLB): 0.9 sec

Buildings that have a fundamental period less than 1 second are defined as rigid by ASCE 7. These buildings need not consider a dynamic wind response. The studies suggest that buildings 15 stories and less need not consider wind dynamics by code if link beams are used. This height is reduced to 10 stories if shear walls are not coupled with link beams.

Net Uplift Due to Wind

The following are the peak ultimate uplift forces at the corners of the lateral load resisting system.

- 42 Story: 1,000 kips
- 30 Story: 400 kips
- 20 Story: 150 kips; 20 Story (NoLB): 300 kips
- 15 Story: No Uplift; 15 Story (NoLB): 150 kips
- 10 Story: No Uplift; 10 Story (NoLB): 50 kips

The wall panels for the no link beam schemes require uplift resistance to restrain local wall panel in-plane bending. The reported values do not reveal this the additional uplift resistance required at the ends of individual wall segments.

Differential Column and Core Shortening

The differential shortening reported is the maximum difference between the core and columns at the highest occupied floor. The value is the long term relative displacement assuming a creep factor of 1.5 times the elastic relative displacement. Elastic relative displacement is assumed to be corrected in the construction process.

- 42 Story: 3.2 in
- 30 Story: 1.8 in
- 20 Story: 1.0 in; 20 Story (NoLB): 1.0 in
- 15 Story: 0.6 in; 15 Story (NoLB): 0.6 in
- 10 Story: 0.3 in; 10 Story (NoLB): 0.3 in

Material Quantities

The average quantity of materials used on a per square foot basis are similar for each building height studied (within 10%). This is because the majority of the materials are used in the floor framing which is nearly identical regardless of building height. Another reason the materials are similar is because the shear walls require the second largest amount of material and the proposed scheme is very efficient and thus controlled by minimum thicknesses in many cases. Thus, it is expected that the shortest buildings could save 10% of the timber quantity and 20% of the rebar reinforcing quantity on a per square foot basis relative to the baseline 42 story Prototypical Building.

Foundations

The foundation materials required will be reduced for the shorter buildings. It is expected that each of the buildings studied would require deep foundations due to the soft clays near the surface in Chicago.

B.3 Summary of Height Studies

The above data suggests that the critical design issues are more easily controlled for a building height of 20 stories or less. The use of link beams allows the building to be up to 15 stories tall without experiencing net uplift due to wind or having a fundamental period greater than 1 second. The building can be only 10 stories tall to achieve these goals without the use of link beams. Thus, composite concrete-timber buildings can be categorized as follows:

- Low-rise building: up to 10 stories (aspect ratio < 1). Lateral load resisting systems will be dominated by shear and need not follow tall building design fundamentals to resist overturning moment. Buildings will likely be rigid for wind loads.
- Mid-rise building: 10-20 stories (aspect ratio of 1 to 2). The lateral load resisting system may or may not need to follow tall building design fundamentals to be successful.
- High-rise building: >20 stories (aspect ratio > 2). Lateral load resisting systems will be dominated by overturning moment and should follow tall building fundamentals such as those shown in Appendix A in order to be successful.

Appendix C: Alternate Systems Studied

C.1 Introduction

The system presented in this report is a composite concrete-timber structural system. The reasons for choosing this system are discussed in the main body of the report as well as Appendix A, Fundamental Engineering Principles. In addition to the system presented, a number of alternates and variations were studied as part of the research project. In particular, an 'All-Timber' scheme was studied and the results are presented herein.

C.2 Design Methodology

The following set of design considerations lead to the 'All-Timber' scheme presented in Section C.3. The following design issues are presented in order of importance.

- 1) Cost. The materials used must be minimized in order to get a cost-effective structure. The majority of structural materials will likely be used in the floor framing system. A material quantity target was set at 0.66 cu.ft/sf for the floors in order to be cost competitive with a concrete flat plate building. The following floor framing systems were then considered:
 - (a) Simply supported floors that span from core to perimeter. This requires about 1.1cuft/sf of timber. This exceeds the quantity target and would increase floor-to-floor height. This scheme is not feasible.
 - (b) Fixed/end restrained floors that span from core to perimeter (same as composite scheme). The timber moment connections to core and spandrel beam are impractical. Torsional resistance of the spandrel beam is not reliable. This scheme is not feasible without reinforced concrete or structural steel connections.
 - (c) Interior columns/walls between core and perimeter. This reduces the floor panel span lengths so that they can be designed as simply supported and meet quantity target. Interior elements have other impacts discussed below. This scheme is feasible.
 - Choose option (c), use interior columns and walls to reduce floor span to eliminate the need for fixed end connections and spandrel beams with torsional resistance.
- 2) Strength of Critical Elements. Refer to Appendix A for information on the design of link beams. Two link beam designs were considered:
 - (a) The link beams in an "All-Timber" scheme must be 18" deep by 30" wide in order to meet the load demands. This would also require that the shear walls be 30" wide where the critically stressed link beams are located. This extends too far inside the floor plate and units and therefore this scheme is not feasible.
 - (b) The link beams could be designed with steel plates laminated within the beams and adjacent shear walls. This scheme loses some of the purity of an "All-Timber" scheme but makes building more usable. This scheme is feasible.
 - Choose option (b), use steel plates laminated within timber link beams.

- 3) Uplift Resistance. The 'All-Timber' scheme must resist approximately two times the uplift experienced by the composite scheme proposed. This is caused by 1) the requirement for interior columns which take gravity loads away from the lateral load resisting system and 2) the reduced weight of the 'All-Timber' scheme relative to the composite scheme with concrete joints. Two uplift connection strategies were considered for the 'All-Timber' scheme:
 - (a) The timber wall panels could be connected with steel side plates and timber rivets. The number of rivets becomes quite large and is undesirable. The steel plates outside of the timber must be fire proofed which is not desirable.
 - (b) Vertical steel plates could be laminated within the shear wall panels. Connections could be bolted together at timber leave-outs. Leave outs require local fire proofing.
 - Choose option (b), use steel plates laminated within timber shear walls.

- 4) Lower Level Design. The plaza, substructure, and foundations were designed as concrete primarily for durability concerns and the high load carrying capacity needed at ground level to support construction activities. Also note that a concrete transfer structure is needed at L02 if the interior columns from the typical levels are not permitted at the plaza and basement levels.

C.3 'All-Timber' System Description

Structural System Diagram

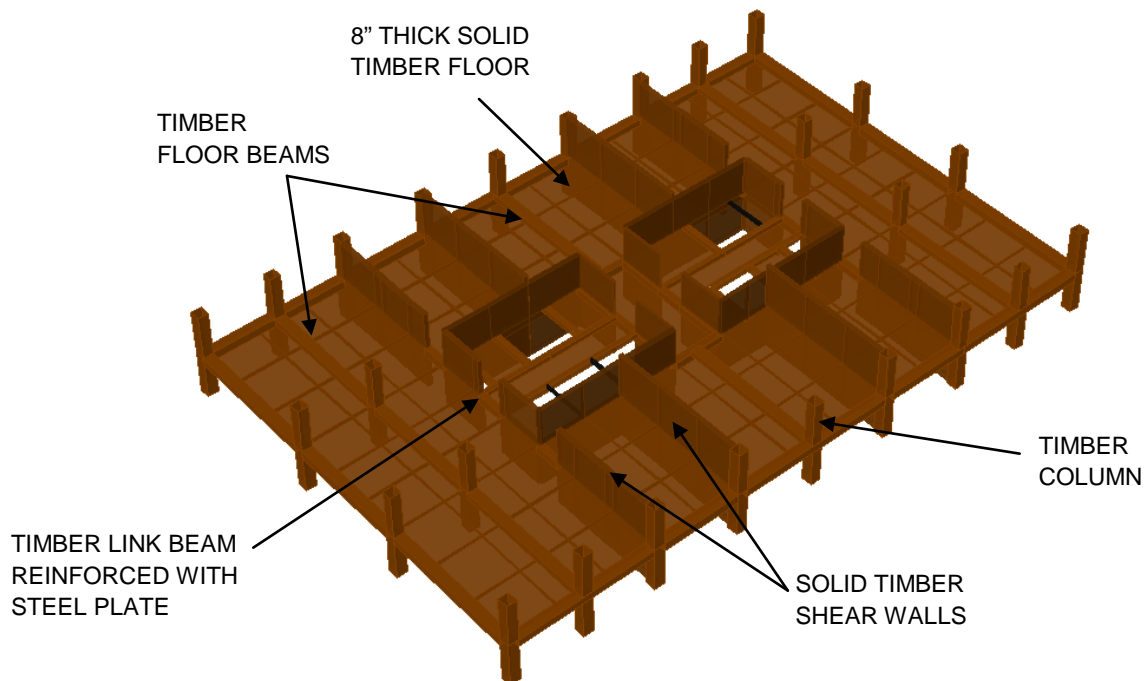

Figure C.1: 'All-Timber' Structural System Diagram

Gravity Framing System

The gravity framing system of the 'All-Timber' design consists of solid timber floor panels that span between shear walls and beams. Because of their pinned ends, the maximum span of the floors is typically limited to 18ft to keep the floor thicknesses at 8". Gravity columns and beams are introduced between the shear wall core and perimeter columns to limit the spans.

Lateral Load Resisting System

The lateral load resisting system consists of solid timber shear walls and timber link beams. The timber link beams and walls are enhanced with steel plates laminated within the elements at locations of high stress. These locations include the critical link beams connecting the North-South shear walls and areas of net uplift on the shear walls.

Lower Level and Foundation System

The lower levels consist of reinforced concrete framing. The foundations are reinforced concrete belled caisson foundations.

Quantities

The following quantities are estimated for the Prototypical Building using an 'All-Timber' scheme. The percentage following the reported quantity is the ratio of materials to the Prototypical Building using the proposed 'Concrete Jointed Timber Frame' scheme.

Sub & Superstructure:

Timber: 1.22 cu.ft/sf	(153%)
Concrete: 0.07 cu.ft/sf	(28%)
Reinforcement: 0.4 psf	(36%)
Structural Steel: 0.7 psf	(233%)

Foundations:

Concrete: 0.08 cu.ft/sf	(89%)
Reinforcement: 0.1 psf	(100%)

C.4 Comparison Summary of Proposed and 'All-Timber' Scheme Studied

The 'All-Timber' scheme studied requires more column and wall elements within the units to shorten the floor spans and achieve the reported quantities. The advantage of providing these elements was a reduction in timber quantities and floor-to-floor height compared to an 'All-Timber' scheme which has floors that span from the core to perimeter. The additional vertical elements are often governed by minimum sizes which adds more material per unit area. This additional material caused the 'All-Timber' scheme studied to require more material than the composite concrete-timber scheme documented for the Prototypical Building. Another disadvantage of providing these additional elements is reduced flexibility of interior layouts and increased net uplift due to wind in the lateral load resisting system.

The increased material quantities and decreased architectural flexibility of the 'All-Timber' scheme studied were the controlling factors in choosing the composite concrete-timber scheme as the primary system documented in this report.

Appendix D: Adaptation for High End Condominiums

D.1 General

The flexibility of the structural system was tested by studying an adaptation for a high end condominium lease depth. The primary changes include adding 7ft to the lease span between the core and exterior wall and increasing the floor to ceiling height to 9'-6" from the 8'-1" at the Benchmark Building.

D.2 Adaptation Requirements: Ref. Sketch I-07

The following changes need to be considered in the design of the structure:

1. Lease depth of 35'-7". This increases the span by 7ft (25%).
2. Plan dimensions of 98 ft by 138 ft. This is increased from 84 by 124ft.
3. Floor to floor height of 11'-1". This is an increase from 9'-0" which matched the benchmark building floor-to-ceiling height.

D.3 Gravity Framing System Adaptation

The span has increased which places additional demands on the floor. One choice would be to increase the thickness of the floor panels by 25% to span the longer length. This approach contradicts the goal of minimizing materials in the interest of cost competitiveness. The floor framing system for this building could instead utilize the alternate floor schemes discussed in Section 2.4 such as the ribbed floors to maintain material economy.

D.4 Lateral Load Resisting System Adaptation

The wind loads on the lateral load resisting system would increase for the high end condominium by the following amounts:

1. The building would be 11% wider, increasing the overturning moment by 11%.
2. The building would be 23% taller, increasing the overturning moment by 52%
3. The total overturning moment would increase by approximately 70%.

The resistance to wind loads would also increase due to the longer shear walls in the critical North-South direction. The longer shear walls increase the lateral load resisting system stiffness (moment of inertia) by approximately 50% and strength (section modulus) by approximately 30%. It can be seen from a comparison of these numbers that the increase in wind loads for the condominium will outweigh the stiffer and stronger lateral load resisting system.

The net uplift experienced by the high end condominium building would be larger than the apartment building because of the increase in wind forces. The system could be designed with more robust uplift resistance or a different structural system could be considered such as a dual system which engages all vertical structural elements.

Appendix E: List of References

Section 1:

- [1.1] Hammond, G. P. and Jones, C. I. "Embodied energy and carbon in construction materials." *Proceedings of the Institution of Civil Engineers - Energy*, 161 (2). 2008. pp. 87-98.
<http://dx.doi.org/10.1680/ener.2008.161.2.87>
- [1.2] Lawson, W. R. "LCA and embodied energy: some contentious issues." *Proceedings, Seminar on Embodied Energy: the current state of play*. 1996.
- [1.3] "2010 Revision of World Urbanization Prospects: The 2010 Revision, Highlights" http://esa.un.org/unpd/wpp/JS-Charts/pop-urban-percent_0.htm. Accessed: January 8, 2013.
- [1.4] IPCC, 2007: *Climate Change 2007: Synthesis Report*. Contribution of Working Groups I, II and III to the Fourth Assessment Report of the Intergovernmental Panel on Climate Change [Core Writing Team, Pachauri, R.K and Reisinger, A. (eds.)]. IPCC, Geneva, Switzerland, 104 pp. 2007.
- [1.5] "BS PAS 2050:2011" British Standards Institution, London, UK, 2011.
- [1.6] Brandao, M., and Levasseur A., "Assessing Temporary Carbon Storage in Life Cycle Assessment and Carbon Footprinting," JRC Technical Report of Proceedings, October 7-8, 2010. Ispra, Italy. 2010.
- [1.7] Erlandsson, M., and Borg, M., "Generic LCA-methodology applicable for buildings, constructions and operation services—today practice and development needs," *Building and Environment*. 38 pp. 919-938. 2003.
- [1.8] Puettmann, M.E., and Wilson, J.B., "Life-Cycle Analysis of Wood Products: Cradle-To-Gate LCI of Residential Wood Building Materials." *Wood and Fiber Science*. Vol. 37 Corrim Special Issue. 2005. pp18-29.
- [1.9] Puettmann, M.E., Bergman, R., Hubbard, S., Johnson, L., Lippke, B., Oneil, E., and Wagner, F., "Cradle-to-Gate Life-Cycle Inventory of US Wood Products Production: CORRIM Phase I and Phase II Products," *Wood and Fiber Science*, 42(CORRIM Special Issue), 2010, pp. 15–28 2010.
- [1.10] Puettmann, M.E., Oneil, E., Milota, M.R. and Johnson. L.N, "Cradle to Gate Life Cycle Assessment of Glue-Laminated Timbers Production from the Pacific Northwest. CORRIM Report Update. January 2013. 25pp.
- [1.11] "Buildings Energy Data Book," United States Department of Energy, D&R International, Ltd. March, 2012. <http://buildingsdatabook.eren.doe.gov/> Accessed: January 8, 2013.
- [1.12] Ali, M and Armstrong, P "Overview of Sustainable Design Factors in High-Rise Buildings," *Proceedings of CTBUH World Congress 2008*.

Section 2:

- [2.1] American National Standards Institute and APA – The Engineered Wood Association. PRG 320, Standard for Performance-Rated Cross-Laminated Timber. 2011.
- [2.2] American Institute of Steel Construction. Design Guide Series 11, Floor Vibrations Due to Human Activity. 2003.
- [2.3] FPIInnovations and Binational Softwood Lumber Council. CLT Handbook, US Edition. Chapter 7. 2013.
- [2.4] American Concrete Institute. Committee 318, Building Code Requirements for Structural Concrete and Commentary. 2008.
- [2.5] American National Standards Institute / American Wood Council: National Design Specification for Wood Construction with Commentary. 2012.

Section 3:

- [3.1] City of Chicago. Municipal Code of Chicago, Chicago Building Code. 2012
- [3.2] International Code Council. International Building Code. 2012.
- [3.3] International Code Council. Performance Code for Buildings and Facilities. 2012.
- [3.4] FPIInnovations and Binational Softwood Lumber Council. CLT Handbook, US Edition. Chapter 9. 2013.

Section 4-5: N/A

Section 6:

- [6.1] Smith, R. “Interlocking Cross-Laminated Timber: Alternative Use of Waste Wood in Design and Construction.” (2011). 2011 BTES Conference: Convergence and Confluence. 2001. 22pp.
- [6.2] Puettmann, M.E., and Wilson, J.B., “Life-Cycle Analysis of Wood Products: Cradle-To-Gate LCI of Residential Wood Building Materials.” *Wood and Fiber Science*. Vol. 37 Corrim Special Issue. 2005. pp18-29.
- [6.3] Puettmann, M.E., Bergman, R., Hubbard, S., Johnson, L., Lippke, B., Oneil, E., and Wagner, F., “Cradle-to-Gate Life-Cycle Inventory of US Wood Products Production: CORRIM Phase I and Phase II Products,” *Wood and Fiber Science*, 42(CORRIM Special Issue), 2010, pp. 15–28. 2010.

- [6.4] Puettmann, M.E., Oneil, E., Milota, M.R. and Johnson. L.N, “Cradle to Gate Life Cycle Assessment of Glue-Laminated Timbers Production from the Pacific Northwest. CORRIM Report Update. January 2013. 25pp.
- [6.5] Hammond, G. P. and Jones, C. I. “Embodied energy and carbon in construction materials.” *Proceedings of the Institution of Civil Engineers - Energy*, 161 (2). 2008. pp. 87-98.
<http://dx.doi.org/10.1680/ener.2008.161.2.87>
- [6.6] Lawson, W. R. "LCA and embodied energy: some contentious issues." *Proceedings, Seminar on Embodied Energy: the current state of play*. 1996.
- [6.7] “Timber Carbon Footprints v1,” TRADA: Construction Briefings, December, 2009 13pp.
- [6.8] National Ready Mixed Concrete Association. “NRMCA 2PCO2: Concrete CO2 Fact Sheet.” 13pp. June, 2008.
- [6.9] Concrete Joint Sustainability Initiative. “P1: Embodied CO2 of UK Cement, Additions and Cementitious Material.” 3pp. November, 2008
- [6.10] Jones, R., McCarthy, M., and Newlands, M., “Flay Ash Route to Low Embodied CO2 and Implications for Concrete Construction.” *2011 World of Coal Ash Conference Proceedings*. May 9-12, 2011. Denver Co, USA. 14pp.
- [6.11] Kaethner, SC., and Burridge, JA., “Embodied CO2 of structural frames,” *TheStructuralEngineer*, May, 2012, pp33-40.
- [6.12] Sansom, M., and Pope, R., “A comparative embodied carbon assessment of commercial buildings,” *TheStructuralEngineer*, October, 2012, pp. 38-49.
- [6.13] Upton, B., Miner, R., Spinney, M. and Heath, L., “The greenhouse gas and energy impacts of using wood instead of alternatives in residential construction in the United States,” *Biomass and Bioenergy*, Vol. 32, pp.1-10.
- [6.14] Gustavsson, L., Joelsson, A., and Sathre, R., “Life cycle primary energy use and carbon emission of an eight story wood-framed apartment building,” *Energy and Buildings*, Vol. 42, 2010. pp. 230-242.
- [6.15] Lawson, W. R. "LCA and embodied energy: some contentious issues." *Proceedings, Seminar on Embodied Energy: the current state of play*. 1996.
- [6.16] Brandao, M., and Levasseur A., “Assessing Temporary Carbon Storage in Life Cycle Assessment and Carbon Footprinting,” *JRC Technical Report of Proceedings*, October 7-8, 2010. Ispra, Italy. 2010.
- [6.17] Erlandsson, M., and Borg, M., “Generic LCA-methodology applicable for buildings, constructions and operation services—today practice and development needs,” *Building and Environment*. 38 pp. 919-938. 2003.
- [6.18] “BS PAS 2050:2011” British Standards Institution, London, UK, 2011.

- [619] IPCC, 2007: *Climate Change 2007: Synthesis Report*. Contribution of Working Groups I, II and III to the Fourth Assessment Report of the Intergovernmental Panel on Climate Change [Core Writing Team, Pachauri, R.K and Reisinger, A. (eds.)]. IPCC, Geneva, Switzerland, 104 pp. 2007.
- [6.20] Sedjo, R., and Sohngen, B., "Forestry Sequestration of CO2 and Markets for Timber," Resources for the Future Discussion Paper 00-35, September 2000, 86pp.
- [6.21] Haselbach, L., "Potential for Carbon Dioxide Absorption in Concrete," Journal of Environmental Engineering, ASCE, Vol 125. pp465-472. 2009
- [6.22] I. Dincer et al. (eds.), *Global Warming*, Chapter 23 "Embodied Carbon: The Concealed Impact of Residential Construction" Green Energy and Technology, Springer Science and Business Media, LLC 2010 pp. 367-384.
- [6.23] FPInnovations and Binational Softwood Lumber Council. CLT Handbook, US Edition. Chapter 11. 2013.
- [6.24] SLOAPCD. *CEQA Air Quality Handbook: A Guide for Assessing the Air Quality Impacts for Projects Subject to CEQA Review*, Air Pollution Control District. 36pp. 2003.
- [6.25] Project Management for Construction: Labor, Material and Equipment Utilization. 30pp. http://pmbook.ce.cmu.edu/04_labor,_material,_and_equipment_utilization.html. Accessed 5/18/2009.
- [6.26] Section 13.2.3, Heavy Construction Operations, U.S. EPA, Compilation of Air Pollutant Emission Factors, Volume I: Stationary, Point and Area Sources, AP-42, 5th Edition, January 1995.

Sections 7-8: N/A

Appendix A:

- [A.1] American National Standards Institute / American Wood Council: National Design Specification for Wood Construction with Commentary. 2012.

Appendices B-D: N/A